

DEXRON®-VI

Although DEXRON-VI was introduced into production starting with 2006 model year vehicles (see bulletin 04-07-30-037D), there are still some misunderstandings about it. Here are some facts to help clear up these misunderstandings.

Since GM introduced the first service-fill specification for automatic transmission fluid (ATF) in 1949, it has been necessary periodically to upgrade the specification as part of a continuous improvement strategy. The upgrading process ensures that available service fill fluids are of an appropriate quality for use in transmissions that have been designed around the improved factory fill fluid performance.

IMPORTANT: As with previous upgrades, DEXRON-VI fluids are designed to be backward compatible with earlier transmission hardware. But more important, earlier type fluids are **NOT FORWARD COMPATIBLE** with transmissions that were designed to use DEXRON-VI.

DEXRON-VI can be used in any proportion in past model vehicles equipped with an automatic transmission, in place of DEXRON-III (for instance, topping off the fluid in the event of a repair or fluid change). DEXRON-VI is also compatible with any former version of DEXRON for use in automatic transmissions.

TIP: Simply topping off the fluid is adequate, but a full drain and replacement is preferred, to obtain the full benefit.

IMPORTANT: DEXRON-VI Automatic Transmission Fluid (ATF) is the only approved fluid for warranty repairs for GM transmissions requiring DEXRON-III or prior DEXRON transmission fluids.

TIP: Any vehicle that previously used DEXRON-III for a manual transmission or transfer case should now use p/n 88861800 (88861801 in Canada) Manual Transmission and Transfer Case Fluid. And power steering systems should now use p/n 89020661 (89021183 in Canada) Power Steering Fluid.

TIP: Since some early bulletins were issued, further validation has taken place and certain transfer cases and manual transmissions now DO use DEXRON-VI, so it's important to refer to the owner manual for appropriate recommendations.

All licenses for DEXRON-III expired at the end of 2006 and will not be renewed. Fluids sold in the



market after that date bearing claims such as "suitable for use in DEXRON-III applications" or similar wording should be avoided, because 'DEXRON-III' fluids are no longer checked and policed by GM and therefore may not be the originally tested and approved formulation.

ADVANTAGES OF DEXRON-VI

GM uses an ATF for factory fill that provides significantly improved performance in terms of friction durability, viscosity stability, aeration and foam control, and oxidation resistance. In addition, the fluid has the potential to enable improved fuel economy and

continued on page 2



Contents

DEXRON-VI	1
ASTRA Programming Fails	1
Non-OEM Oil Change Concerns	3
Battery Testing Using Conductance Tester ..	4
IP Accessory Trim Plate - Malibu	4
Hunter GSP9700 Tire and Wheel Balancer	5
Navigation Radio Restriction Updated	5
AM/FM Radio Reception	6
No Crank	6
Remote Vehicle Start Inoperative	6
XM Antenna	6
Moisture in Headlamps	7
Brake Pad Cracks	7
Fix It Right the First Time	8
Know How Broadcasts for June	8

Techline News

ASTRA Programming fails

On a 2008-09 Saturn ASTRA, occasionally during a programming event for updating or replacement of a module, programming may fail after entering the Code Index.

When using the white labeled VCI/Tech 2 card (32MB), certain programming functions may not complete

properly. This issue is currently under investigation by engineering.

To properly program a Saturn ASTRA, use only the blue labeled VCI/Tech 2 card (32MB) or the previous 10MB until further notice.

- Thanks to Jim Loomis



DEXRON®-VI - continued from page 1

extended drain intervals. The service fill specification for a fluid meeting these standards is designated as DEXRON-VI.

When compared with earlier automatic transmission fluids, DEXRON-VI offers these improvements and benefits:

- enhanced performance of both new and older transmissions
- longer ATF life (160,000 km/100,000 miles normal, or 80,000 km/50,000 miles severe). It is important to refer to the owner manual because certain vehicles recommend a normal service drain interval of 150,000 miles (240,000 km).
- consistent shift quality throughout the life of the transmission
- extended transmission life.

To achieve these benefits, DEXRON-VI offers significant improvements in these operating characteristics:

Friction Stability (improved 100%) – Friction describes how the fluid behaves when transmission clutches or bands are engaged. A fluid with poor friction characteristics leads to grabbing, chattering and slipping. DEXRON-VI also offers a 120% improvement in clutch durability.

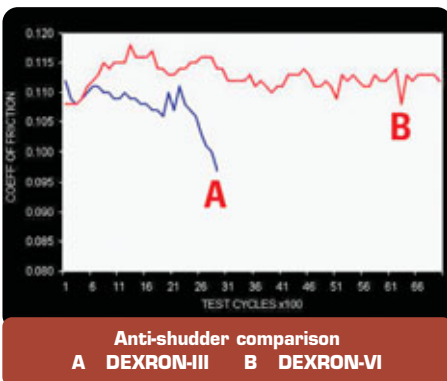

Viscosity Stability (greatly improved) – Viscosity is a description of how thick or thin a fluid is at various temperatures. In a hydraulic system, components can function sluggishly or improperly when viscosity is wrong. As determined by comparison testing,

DEXRON-VI maintains an almost constant viscosity over time, while the viscosity of DEXRON-III degrades considerably.

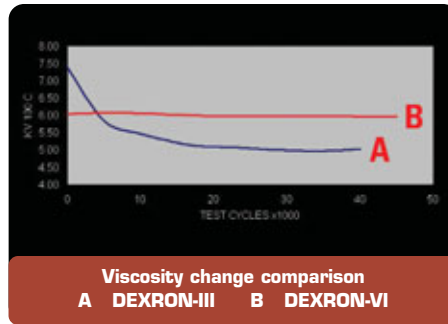

Foaming Resistance (improved 150%) – Automatic transmission fluid may contain air in three forms – dissolved, entrained (aeration) and foam. Oil containing air doesn't do anything very well – lubrication is affected, heat transfer in affected and pressures are unstable. Anti-foam additives are used to control and limit the effects of air in the fluid.

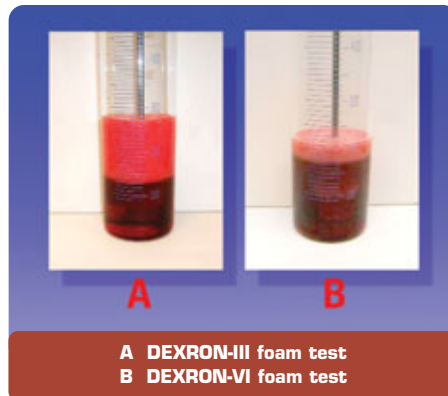

Oxidation Resistance (improved 100%) – Oxidation describes the length of time it takes for a fluid to reach the end of its useful life. Oxidation generally occurs more quickly at higher temperatures. And oxidation has an effect on how long a fluid can be used before replacement is necessary.

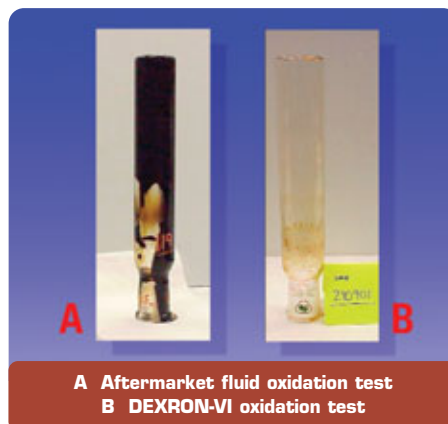

TIP: Just because another auto maker does not require use of DEXRON-VI, this does not imply that their required fluid is in any way inferior to or better than DEXRON-VI. It simply means that the other auto maker has established its own, unique fluid requirements. Their transmissions may be built with different materials, and may be designed to perform in different ways, neither of which is necessarily inferior to or better than GM's transmissions, just different. Variables include the material used for friction surfaces, the material used for reaction surfaces, the types of control mechanisms and the characteristics of the factory fill fluid. This means that each manufacturer must tailor their transmission fluid requirements to meet the needs of their own transmissions. And a fluid may cause entirely different performance when installed into transmissions of different designs.

COUNTERFEIT PRODUCTS

Beware products that claim to be DEXRON-VI but are not; for instance, some products claim to be multi-purpose. And beware the products which claim to provide DEXRON-VI characteristics when added to other ATFs. Unlicensed products have not been tested by GM to determine whether they meet GM's specifications.

ADDITIVES

DEXRON-VI is formulated to meet and exceed GM's specifications and requirements. Additives are not needed and are not recommended.

The best thing that can happen when using an additive is that it will do nothing. At worst, an additive can ruin the transmission.

DEALING WITH CONTAMINATION

Anything but DEXRON-VI in the automatic transmission is considered a contaminant. Typically, a customer or other service facility may add fluids other than DEXRON-VI. This includes aftermarket additives – they are not needed and should not be used. In case like this:

- drain the transmission fluid
- flush the system with DEXRON-VI (NOT solvent)
- fill the system with the correct amount of DEXRON-VI.

FLUSHING

Many aftermarket flushing systems rely on solvents, which essentially may be considered contaminants. The effects of these contaminants may lead to transmission failure.

Non-OEM Oil Change Concerns

Refer to bulletin 02-07-30-052E and also document 1601517 for the complete story on using the Automatic Transmission Oil Cooler Flush And Flow Test Essential Tool J 45096 TransFlow. Here are some highlights.

Two significant features of the J 45096 are (1) that it uses DEXRON-VI, not solvent, as a flushing agent, and (2) that it injects high pressure air into the fluid stream to agitate the ATF oil to enhance removal of contaminated ATF and debris.

TIP: It is important to flush the system in both directions (back-flush and forward-flush). There are instructions in SI to explain how to make the proper hookups for both directions.

There are also instructions in SI explaining which adapters to use for various transmissions.

TIP: It is necessary to fabricate adapters for Vibe, Wave and Aveo, using instructions in SI. Also, although these vehicles have a slightly different transmission oil requirement, the small amount of DEXRON-VI remaining in the system after flushing is compatible.

In addition to the flushing capability, the J 45096 also has a digital flow meter to check and indicate the flow capability of the ATF oil cooling system.

Oil temperature has a direct bearing on flow rate, so SI explains several ways to ensure that the DEXRON-VI in the storage reservoir is suitably warm for an accurate test. And there is a table showing the minimum flow rate at various temperatures and for both steel and aluminum coolers.

– Thanks to Roy Fewkes and Joan Petit

GM Engineering has seen examples of sub-standard non-OEM oil change parts used in customers' vehicles. The following information points out the flaws of some of these components, and how they were identified.

OIL FILTERS

The filtering capacity of an oil filter is dependent on the surface area of the filter paper. This is dependent on the number of pleats, or folds. In the photo, the AC Delco filter on the left has 43 pleats in the filter paper. The aftermarket filter on the right is marketed as a premium filter. It has only 35 pleats. It has a metal joining tab for the filter element, which further reduces the filter surface area.

Some aftermarket filters are manufactured with inferior parts which can damage an engine. For instance, the orange rubber material from an oil filter anti-drainback valve has migrated to the oil passages of the engine in the next photo. At best, the material will restrict flow and slowly cause damage. At worst, it will block passages and quickly damage the engine.

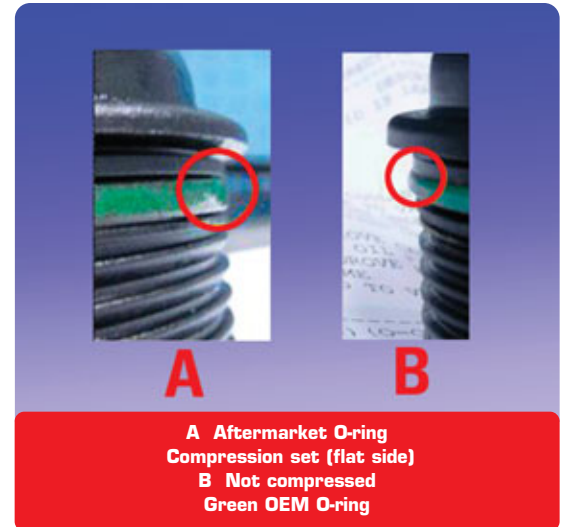
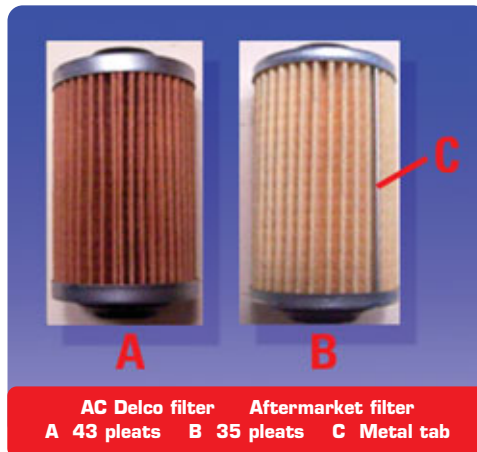

OIL FILL CAP

GM has also seen issues with aftermarket oil filter caps. The one in the photo is from an Ecotech engine.

The customer concern was an oil leak from the Ecotech oil filter cap O-ring. The O-ring was not OEM.

TIP: OEM O-rings are not available separately from the cap. They are designed for the life of the engine.

All OEM O-rings are green, and the majority of non-OEMs are black. A green O-ring with a flat on one side is a non-OEM. Green OEM O-rings will not develop a flat side as a result of the normal compression during sealing (also known as a compression set).

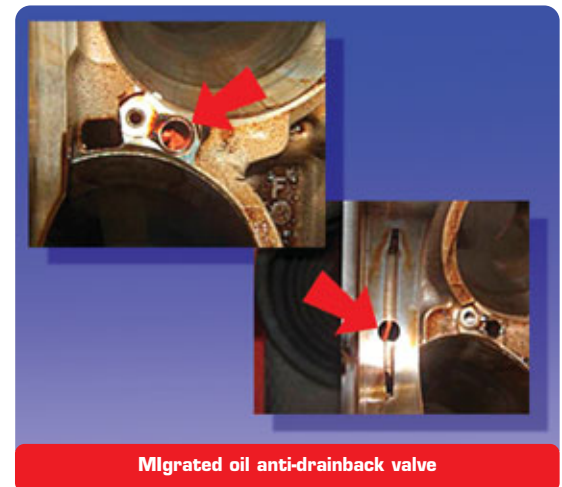

OIL DRAIN PLUGS

It can be very difficult to distinguish the differences between an OEM and aftermarket drain plug and seal.

However, be aware that many of the aftermarket seals are not designed to handle the extended oil change intervals and the drain plugs may not have the correct design to provide good sealing between the seal and the oil pan.

– Thanks to Dave Peacy



Battery Testing Using Conductance Tester

TESTING A NEW BATTERY

A new battery is considered "unformed" until it has been through several discharge/charge cycles. This means a new, unformed battery will not be capable of producing its optimum current and cold cranking amps (CCA). If an "unformed" battery is tested using the Midtronics J-42000 or similar Conductance Tester, the resulting CCA may be lower than indicated on the battery's rating label. This could lead to condemning an otherwise good battery.



voltmeter (DVOM) to be sure there is adequate voltage to start the vehicle. The battery should be in service for several days before performing a conductance test.

Battery In a New Vehicle – The battery in a new vehicle has likely been formed due to multiple engine starts between the end of the assembly line and the time the vehicle is driven into the service department for pre-delivery inspection.

BATTERY TESTING PROCEDURES

Follow these tips when using the J-42000, to ensure accurate test results. Using unapproved adapters or improper test procedures can lead to failing test results for batteries that are not defective.

Be sure the battery in the tester is good or you may get inaccurate results. To check the conductance tester, be sure OCV on the tester matches the OCV measured with a known-good DVOM (may vary slightly due to different internal resistance).

Be sure to get good connections between the battery terminals and the tester clamps.

If testing the battery in the vehicle with the cables attached, follow the procedure in SI for proper results. If correct connections to the battery terminal bolts in the vehicle are in doubt, disconnect the cables and install the test adapters on the terminals.

TIP: Each tester clamp has two jaws. Each jaw is wired to a different part of the tester, and it is essential that both jaws make good contact.

TIP: When using an adapter, be sure the adapter makes good contact with the lead terminal surface on the battery.

Side Terminal Battery – Never use steel bolts, nuts, washers, etc., when testing a side terminal battery. Use only the adapter included with the J-42000 tester.



Side terminal adapter

The coating on other adapters may affect the tester's accuracy.

– Thanks to Brad Busboom

IP Accessory Trim Plate – Malibu

On the Malibu, if the IP accessory trim plate is removed incorrectly, it may be damaged. There are 2 hidden screws and 8 clips. Here are some tips.

Several components are "shingled" (meaning they are overlapped), and must be removed in the correct order for access to the IP accessory trim plate.

TIP: Refer to SI for details: > Body Hardware and Trim > Instrument Panel and Console Trim > Repair Instructions.

1. Remove the shift control knob.
2. Use a flat bladed plastic trim tool to release the retaining clips on the bottom side of the front floor console accessory trim plate. Remove the trim plate. Disconnect electrical connections.

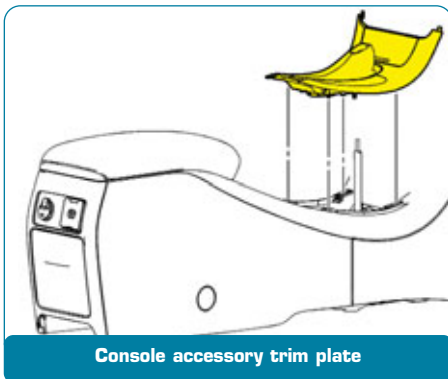

Console accessory trim plate

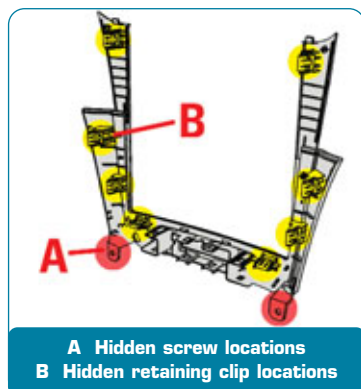

A Hidden screw locations
B Hidden retaining clip locations

3. This gives access to remove two hidden screws at the bottom of the IP accessory trim plate.
4. Use a flat bladed plastic trim tool to release the retaining clips on the back side of the IP accessory trim plate. There are three on each side of the opening, and an additional two below the opening. Disconnect electrical connections.
5. Lift the IP accessory trim plate away from the instrument panel.



Prying IP trim plate



Removing IP trim plate

– Thanks to Ali Elhadi

Hunter GSP9700 Tire and Wheel Balancer

TIP: Refer to bulletin 00-03-10-006D for details on radial force variation and service procedures for dealing with it.

The Hunter GSP9700 Tire and Wheel Balancer provides a means of balancing wheel and tire assemblies. In addition, it also provides several diagnostic measurements. Two of these diagnostic measurements are Road Force Measurement™ and Quick Match™.

Used correctly, these diagnostic measurements can assist in analyzing tire performance. Used incorrectly, they can lead to misinterpretation, wasted effort, and ultimately to customer dissatisfaction.



BALANCE vs. RADIAL FORCE VARIATION

Two characteristics of a wheel/tire assembly have a profound effect on vehicle "ride" – balance and radial force variation. Both are addressed by the Hunter GSP9700 Tire and Wheel Balancer.

Balance is related to the mass of the wheel/tire assembly, and radial force is related to the effective "roundness" of the assembly. Both can contribute to vibration being transmitted into the vehicle. Balance is addressed by installing weights to the perimeter of the wheel to counter the imbalance. Radial force is addressed by match mounting or by replacing a wheel or tire.

Balance measures how the wheel/tire assembly's mass is distributed around its rotating axis. This measurement is accomplished by spinning the assembly at high speed. Balance is checked and corrected first. If vibration or shake still exists, radial force variation may be the cause. Often, vibration issues are corrected by simply balancing the assembly, Radial force variation can also be diagnosed while the assembly is on the machine.

Radial force measures how "round" the assembly is when rolling under a load. Variations in sidewall stiffness, for instance, have an effect on radial force. Radial force measurement must be done under a load. The most common ride concern involving radial force variation is highway speed shake on smooth pavement. A stiff section of sidewall will affect the rolling radius of the tire, causing a vibration once per revolution (or in some cases, 2nd, 3rd or 4th order inputs).

The GSP9700 load roller applies a force of up to 1250 pounds against the rotating tire/wheel assembly as it performs the Road Force Measurement. The GSP9700 measures loaded radial runout of the tire/wheel assembly within 0.002-inch. The measurements of loaded radial runout are converted to Road Force Measurement in pounds, kilograms or Newtons.

QUICK MATCH vs. ROAD FORCE

TIP: The GSP9700 requires periodic calibration to ensure accurate wheel/tire measurements.

Both Quick Match and Road Force Measurement are performed by measuring deflection of the axis of the wheel/tire assembly when the tire is contacted by a roller. But there are significant differences between the processes and in what you can learn from the test results.

Quick Match, as the name implies, provides a quick evaluation of the wheel and tire, without taking the time required for a full Road Force evaluation. In about seven seconds, Quick Match measures the lightly loaded radial runout and displays the result in thousandths of an inch. This feature is best used as a quick check of wheel/tire assembly (such as a bead not fully seated) at the point of installation. But for vibration diagnosis, the normal radial force measurements should be used.

TIP: Most tire manufacturers do not recommend evaluating road force variation until the tires have been driven for at least 10 miles (16 km).

Road Force Measurement applies up to 1250 pounds of pressure against the tire to simulate actual driving conditions and test tire uniformity. This diagnostic feature is used to evaluate and locate the cause of a vibration caused by radial force variation.

A wheel/tire assembly that has excess road force may pass the Quick Match test. If Quick Match is used to diagnose tires as the cause of a vibration, the Hunter GSP9700 may not flag a bad wheel/tire assembly and the technician will expend significant resources in an effort to resolve the concern with no positive result.

TIP: Do not use Road Force Measurement to audit new tires. It is intended as a diagnostic tool to minimize radial force variation of the wheel/tire assembly.

HOW TO DISABLE THE QUICK MATCH FEATURE

Here is how to disable the Quick Match feature so it cannot be used accidentally.

1. Press the RESET button twice.
2. Enter the Set Up screen by pressing the center Up/Down arrow button between K2 and K3, then selecting the Setup button.
3. Turn the scroll knob to Select Quick Match.
4. Press the Set Up Selected Item button.
5. Turn the scroll knob to Disabled.
6. Press the OK button.
7. Press the Store Set Up button.

– Thanks to Brad Busboom



Navigation Radio Restriction Updated (U.S. only)

Since September 2008, all navigation radios have been on restriction through the PQC to help identify issues and implement repair and better diagnosis (Bulletin 08-08-44-010D). There is also a 30 day Integrated Center Stack restriction for 2008-09 Cadillac CTS/V which incorporates navigation radio as well as regular radios, to identify and remedy some issues with this relatively new technology.

Change – Effective March 2, 2009 through August 28, 2009, only *current model* navigation units (2009-10) are on restriction.

Another change – Dealers are now instructed to contact TAC (instead of PQC) when a navigation radio is needed. TAC will assist dealerships to confirm diagnosis and offer alternative solutions for more effective repair of consumer vehicles. In this way Complaint - Cause - Correction can be better coordinated with engineering to effectively pinpoint, repair, and publish diagnosis on the various elusive scenarios technicians have with this complex system.

– Thanks to Ward Boyer

AM/FM Radio Reception

The owner of a vehicle with glass-mounted antenna may experience an AM/FM radio reception issue. The rear window glass containing the AM/FM antenna element may have been replaced.

TIP: Although a Cadillac CTS window is shown in the photos, this condition can affect any glass-mounted antenna in a rear or side window.

Before reseating any connections associated with the antenna or radio systems, and before removal or replacement of the antenna modules, radio unit, coaxial cables, power, signal, and ground wires, perform the following inspection and repair.

Remove the necessary trim and parts for inspection of the perimeter of the glass. The minimum clearance for the urethane or primer to any silver printing on the surface of the glass must not be less than 11 mm.

TIP: The urethane and primer are conductive and degrade radio performance.

If the urethane or primer extends over the silver antenna printing, the glass must be replaced.

If the urethane or primer does not extend over the silver antenna printing, remove any urethane or primer along the glass perimeter that does not meet the 11 mm specification.

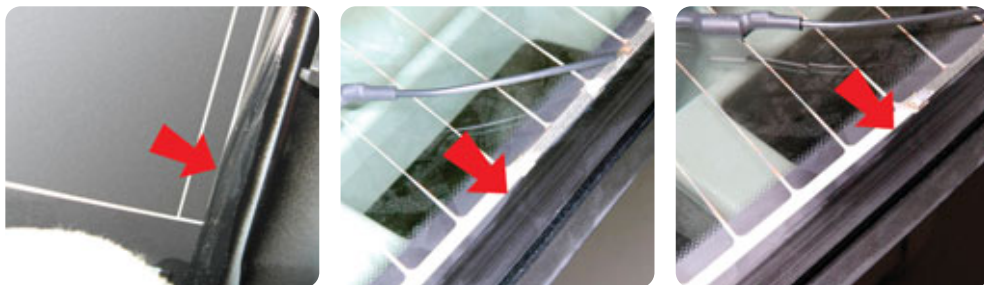

Use extreme caution when eliminating the excess urethane or primer on the glass. Tape the silver antenna printing on the glass with blue painter's tape. Be careful not to damage, cut or scrape any of the silver antenna printing and blackout on the glass. And do not damage or disrupt any electrical connections attached to the glass.

Before reassembly, measure the distance between the urethane or primer and the silver printing on the glass to verify compliance to the specification.

Reassemble the vehicle.

– Thanks to Howard Owens

Remote Vehicle Start (RVS) Inoperative During Cold Weather

Some owners of a Cobalt or G5 with Remote Vehicle Start RPO AP3 may comment on these concerns:

1. Remote start intermittently functions or becomes inoperative. Vehicle will still start if the key is used in the ignition. In many cases, the function resumes when the vehicle warms up.
2. The vehicle theft alarm sounds when using remote start in freezing temperatures. In many cases, the alarm will sound for no reason at all.

TIP: The outside temperatures were below freezing.

In most cases, normal function resumes when either the vehicle warms up or the temperature rises just above freezing. These conditions exhibit themselves in regions where customers drive on roads that have been treated with melting salts for snow in combination with being exposed to subfreezing temperatures.

First confirm that the condition is not caused by a hood that is not closed properly, defective keyless remote or body control module.

If none of these conditions is present, replace the hood latch with a revised hood latch obtained from the Warranty Parts Center.

These latches incorporate a potting seal to prevent water penetration into the electric connector of the latch. Order the latches using the same part numbers as the current service part numbers for these vehicles.

– Thanks to Jim Loomis

No Crank – 2-mode hybrid

On an Escalade, Tahoe, Yukon, Silverado or Sierra with Two-Mode Hybrid System (RPO HP2), you may experience a No Crank concern with multiple codes set in several different modules. After retrieving and recording the codes, you may wonder which codes you should start with first.

When dealing with a No Crank concern, use the following diagnostic approach:

1. First, address codes P1AE2, P1AE4, P1B05, or P1B06 as they are related to the High Voltage System Interlock Circuit for the high voltage system. These codes may occur after a service part has been installed, due to
 - the high voltage disconnect not being fully seated
 - the drive motor generator control module sight shield (PIM cover) not fully seated
 - the transmission 3-phase cable cover connector disconnected.
2. Next, address any CURRENT loss of communication DTCs that create a U code related to the powertrain expansion bus or the high speed LAN bus.
3. Finally, address any low voltage concerns that may be related to a low 12 volt battery.

– Thanks to Paul Radzwillowicz

XM Antenna

All Solstice coupes will be equipped with an XM antenna, whether the vehicle actually has an XM radio or not.



TIP: XM radio is not included in vehicles for Mexico, some Canadian vehicles, and vehicles ordered with the Z0K performance package.

– Thanks to Brad Thacher

GM TechLink is a monthly magazine for all GM retail technicians and service consultants providing timely information to help increase knowledge about GM products and improve the performance of the service department.

Publisher:

R. M. (Bob) Savo
GM Service and Parts Operations
Bob.Savo@GM.com

Editor:

Lisa G. Scott
GM Service and Parts Operations
Lisa.G.Scott@GM.com

Technical Editor:

Jim Horner
jhorner@gpworldwide.com

Desktop Publishing:

5by5 Design
dkelly@5by5dzn.com

FAX number:

1-248-729-4704

Write to:

TechLink
PO Box 500
Troy, MI 48007-0500

GM TechLink on the Web:

GM GlobalConnect

General Motors service tips are intended for use by professional technicians, not a "do-it-yourselfer." They are written to inform those technicians of conditions that may occur on some vehicles, or to provide information that could assist in the proper service of a vehicle. Properly trained technicians have the equipment, tools, safety instructions and know-how to do a job properly and safely. If a condition is described, do not assume that the bulletin applies to your vehicle or that your vehicle will have that condition. See a General Motors dealer servicing your brand of General Motors vehicle for information on whether your vehicle may benefit from the information.

Inclusion in this publication is not necessarily an endorsement of the individual or the company.

Copyright© 2009 General Motors Corporation
All rights reserved.

Moisture in Headlamps – Corvette

Customers may notice moisture formed inside the headlamp lens. This may be caused by the rubber headlamp bulb access covers not being installed properly. There is a separate cover for each of the four headlamp bulbs. If a cover is not properly seated, water can leak into the headlamp housing and condense on the inside of the lens.



High beam cover loose



Low beam cover loose

Be sure all four covers are present and properly seated. If a cover is missing, service replacement parts are available.

Simply press the flange of the cover fully into the locating groove.

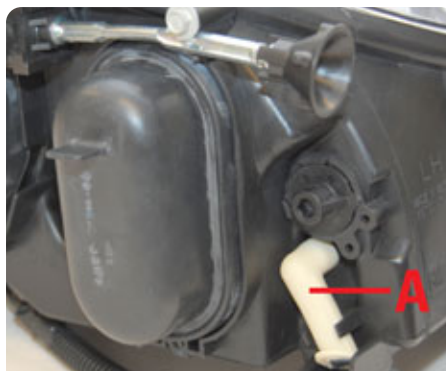

High beam cover installed
A Vent tube

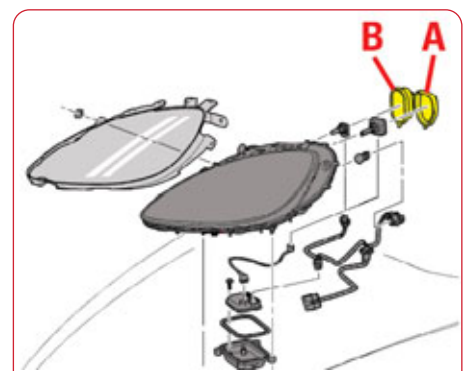

A Cover, Low Beam 12335924
B Cover, High Beam 12335925

After the covers are properly installed and headlamps are turned on, moisture will evaporate and pass from the housing through the vent tube.

– Thanks to Jim Spiker

Brake Pad Cracks

When performing a brake inspection on a 2007-09 Chevrolet Silverado 3500HD or GMC Sierra 3500HD with brake RPO JK4 or JH7, hairline cracks may be noticed in the pad friction material. Cracks in the friction material can occur after the pads have been subjected to high pad temperatures.

These hairline cracks do not affect the operation of the brake system and the pads should not be replaced if only hairline cracks are found.

– Thanks to Jim Will

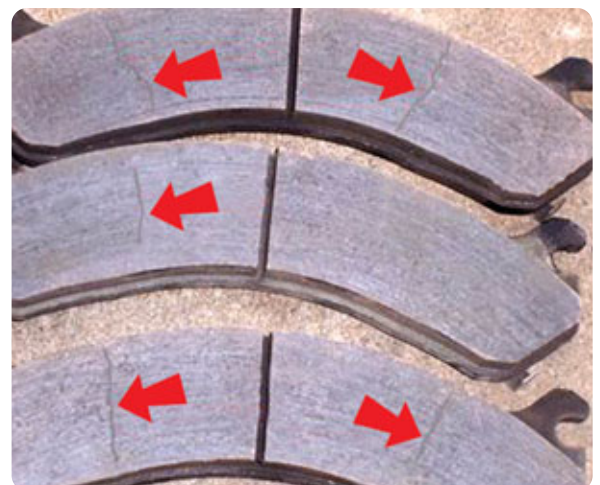



Car Issues – Fix It Right the First Time

Model Year(s)	Vehicle Line(s) / Condition	Do This	Don't Do This	Reference Information / Bulletin
2008-09	HHR – Hard brake pedal	Add vacuum booster pump to system	Don't recalibrate EBCM	09-05-22-001A
2009	CTS – Navigation radio turns on unexpectedly	Install updated radio software	Don't replace radio	08-08-44-019A
2004-09	Malibu, Maxx, G6, AURA – Fuel gauge not reading full, P0461	Repair fuel level sender float	Don't replace fuel level sender or pump module	09-06-04-007
2007-09	SRX, STS, CTS – Information on 6L50 transmission parts	Correctly identify transmission before ordering parts	Don't install parts for 6L80/6L90	09-07-30-005
2009	Lucerne – Rear door handles and locks inoperative	Inspect and align handle, cable and lock linkages	Don't replace latch assembly	09-08-64-005
2008-09	DTS – Windshield pillar garnish molding loose	Remove excess foam, install new fasteners	Don't replace molding	09-08-110-003
2008-09	Z06 Corvette – SES light, P0420, P0430	Reprogram ECM	Don't replace catalytic converters	09-06-04-011A
2009	Aveo, Wave – Intermittent no crank, MIL, DTCs	Reprogram ECM	Don't replace ECM	09-06-04-005
2008-09	CTS – Marks on windshield	Clean with Rhodite compound	Don't replace windshield	09-08-48-002A
2008-09	CTS – No crank, battery dead, draw from memory seat module	Reprogram seat module with SPS	Don't replace module or battery	09-08-50-002
2008-09	CTS – Rear shelf buzz, rattle	Install flocking tape and shim stock	Don't replace speaker	09-08-44-003
2006-08	Aveo, Wave – MIL, DTC after using coolant heater	Reprogram ECM	Don't replace ECM or sensors	09-06-04-010
2008-09	CTS – Sunroof reverses direction during express close	Replace sunroof window and sunshade motor	Don't replace sunroof frame assembly	09-08-64-007
2006-09	Solstice, SKY – Water leak or wind noise from front of top at windshield	Inspect weatherstrip for damage	Don't replace customer damaged part under warranty	09-08-67-006



Truck Issues – Fix It Right the First Time

Model Year(s)	Vehicle Line(s) / Condition	Do This	Don't Do This	Reference Information / Bulletin
2007-08	Sierra, Silverado – Sunroof water leak	Follow tips in bulletin. Rear gutter parts available	Don't replace frame	09-08-57-002
2004-07	Express, Savana – Knock, rattle from engine	Use new p/n for flywheel/flexplate	Don't use old p/ns	08-06-01-023A
2009	Acadia, Enclave, OUTLOOK, Traverse – Intermittent MIL, DTC	Reprogram ECM	Don't replace thermostat	09-06-02-004
2007-09	Fullsize pickups and utilities – Adjusting outside mirrors	Explain how mirrors function	Don't replace mirrors	09-08-64-003
2007-09	Acadia, Enclave, Equinox, G6, Malibu, OUTLOOK, Torrent, Traverse – Transmission fluid leak	Inspect with black light, replace torque converter fluid seal	Don't replace torque converter, case-to-converter housing seal	09-07-30-006
2003-08	Express, Savana – Noise when turning	Replace steering gear	Don't replace power steering pump	03-02-32-003A
1999-2007	Full- and mid-size trucks – ABS light, DTCs, loss of communication with brake module	Reground EBCM	Don't replace brake module	04-05-24-002E

**Know-How
Broadcasts
for
June**

10209.06D Emerging Issues
New Model Features

June 11, 2009 9:30 AM and 12:30 PM Eastern Time

For Web NMF courses, log on to the GM Training Website (www.gmtraining.com). Select Service Know-How/TechAssists from the menu, then choose New Model Features for a selection of courses.



– Thanks to John Miller