

All-Wheel-Drive Rear Differential Clutch

The all-wheel-drive system available on the 2010-2011 SRX and LaCrosse features a Power Take-off Unit (PTU) in the front final-drive that transmits engine torque through a prop-shaft to the Rear Drive Module (RDM). The RDM includes a Torque Transfer Device (TTD), or differential clutch, and an electronic Limited Slip Differential (eLSD). Both are wet, multi-plate clutch units.

The TTD is activated as soon as the vehicle is placed in gear. RDM clutches are applied and ready to transfer torque before acceleration begins. Wheel slip or driveline rotation does not need to be detected before the rear drive is activated, which provides maximum traction immediately. During driving, torque delivery between the axles is varied by a valve in the TTD, which increases or reduces the hydraulic pressure on the wet clutch plates to progressively engage or disengage rear drive. The degree of slip determines the amount of torque transmitted. The eLSD, located alongside the RDM, operates on the same principle as the larger TTD. The electronic control unit functions in concert with the engine, transmission and ABS/ESC control modules.

Servicing the Rear Differential Clutch

If the Service Rear Axle message is displayed on the DIC, use GDS diagnostics to determine which DTCs are set.

TIP: Refer to PIP4731G for additional information regarding replacement of the internal filter when DTC C0403 symptom 62 (AWD Oil Filter Reverse Valve Stuck Open) is set. A calibration update to the Clutch Control Module (CCM) also is required.

After servicing the rear differential clutch filter, the clutch housing must be filled in a specific manner in order to achieve the proper fluid level.

Many times after a clutch filter has been replaced, DTC C0407 symptom 64 (AWD Oil Pump Motor Component Slipping) will set. The single biggest cause of DTC C0407 symptom 64 is low fluid. A low fluid level may be caused by improperly filling the differential clutch or a leak at the pump cover gasket. Do not reuse the old gasket.

continued on page 2

Techline News

End of Support for Windows XP

On January 1, 2011, GM Customer Care and Aftersales will no longer support the use of Windows XP or Internet Explorer 6 on Techline PCs in the dealership.

The new recommended Techline operating system (OS) is Windows® 7 Professional, 32 bit. The recommended web browser is Internet Explorer 8.

Beginning January 1, the new minimum required systems will be Windows Vista Business, 32 bit, and Internet Explorer 7.

TIP: GM requires the use of 32 bit operating systems and business grade hardware. 64 bit operating systems and consumer grade hardware are not supported.

continued on page 2

Contents

All-Wheel-Drive Rear Differential Clutch	1
End of Support for Windows XP	1
Duramax Diesel Glow Plug Replacement	2
GM Goodwrench Technical Assistance Quality Survey	3
No Communication with High Speed LAN Modules	3
2011 Model Year OnStar No Connection Issues	3
2011 Cruze Passenger Presence System	4
Crankshaft Position Sensor Reluctor	5
Electronic Brake Control Module Communication	5
Intermittent Low Power after Turbo Upgrade Kit Installation	5
High Strength Steel Drill Bits	6
Engine Misfires	6
Two-Mode Hybrid Internal Transmission Wiring Harness Repairs	6
Tail Pipe Depressions	7
Two-Mode Hybrid Pickups Cargo Box Noise	7
Radio Display Fogging	7
Fix It Right the First Time	8
Service Know-How	8

All-Wheel-Drive Rear Differential Clutch – continued from page 1

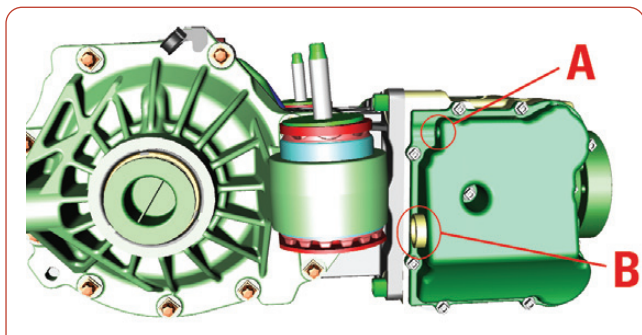

Add 350 ml of differential clutch fluid through the vent opening (A). DO NOT attempt to fill through the cover plug (B).

Fluid Fill

The differential clutch must be filled through the vent fitting opening in the differential clutch cover with 350 ml (12 oz.) of differential clutch fluid, part number 88863349 (in Canada, 88863350). Fluid for the differential clutch and the rear axle are different. Fluids must not be mixed. DO NOT fill the differential clutch through the differential clutch cover plug.

When filling the differential clutch housing after repairs, the fluid must be able to flow over the top of the internal wall of the pump cavity, making it imperative that the fluid is filled through the vent opening with the cover plug installed. The bottom of the cover plug opening and the internal wall are at the same level. If the cover plug is not installed, the fluid will run out of that opening before it can flow over the wall into the pump cavity.

Filling the clutch housing through the vent fitting opening using a syringe with a hose is recommended.

Refer to Service Information Document I.D. 2364449 for the differential clutch fluid replacement procedure.

TIP: Many CCMs and clutch motor pumps have been replaced to correct DTC C0407 symptom 64. These parts will not cause this code to set. Removing the control module and valve will purge some of the air from the pump motor cavity, which will give a false impression that a new control module was the correct repair.

Pump motor current below 2500mA indicates that the pump motor cavity is low on fluid. Verify that all 350 ml of differential clutch fluid was added through the vent fitting opening in the differential clutch cover.

– Thanks to Matt Moore

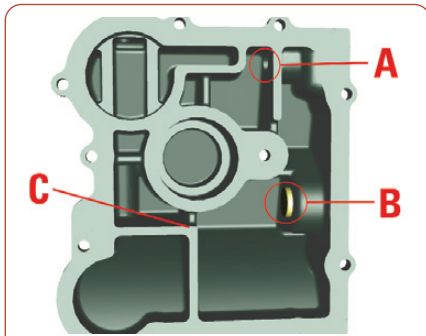

Internal view of clutch housing:
A. Vent opening B. Cover plug
C. Internal wall of pump cavity

Duramax Diesel Glow Plug Replacement

After replacing a glow plug on a 2006-2011 Duramax diesel engine (RPOs LMM, LGH, LML), it may be noted that a P0671-P0678 DTC (glow plug control circuit DTCs for cylinders 1-8) will not clear. This is because the control module will not clear the DTC if the glow plugs are not energized during the next key cycle. To clear the DTC, a scan tool can be used to perform a forced glow service procedure.

TIP: Do not replace the Glow Plug Control Module (GPCM) because the DTCs do not clear after replacing a glow plug. A glow cycle is necessary to allow the GPCM to reset the glow plug resistance calculation, which will clear the DTC. The GPCM will not power the glow plugs if the engine coolant has an elevated temperature (greater than 50° C).

Using a scan tool, it can be seen that the resistance values of the glow plugs will not be reset in the GPCM — and the DTCs will not clear — without a glow cycle on the current engine start.

To perform a forced glow using a scan tool:

1. Perform the necessary repairs
2. Connect a scan tool
3. Turn on ignition 0 and ignition 1
4. Command glow via device control for 1-2 seconds
5. Clear DTCs
6. Disconnect the scan tool
7. Turn off ignition 0 and ignition 1 for 30 seconds
8. Start the vehicle and verify DTCs are not present

The voltage that is applied to the glow plugs during device control is very low at 4 volts. In addition, the GPCM has a maximum glow plug ON time of three minutes. The glow plugs cannot be turned on for a time period longer than three minutes.

Refer to the updated glow plug replacement instructions in the Service Information for additional information.

– Thanks to Brian Fuller

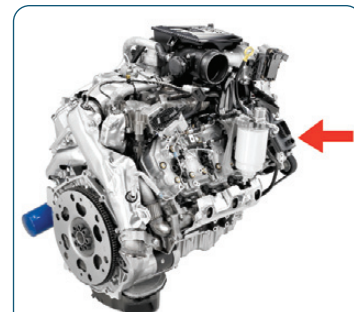

DO NOT replace the Glow Plug Control Module because the DTCs do not clear after replacing a glow plug.

Techline News – continued from page 1

The current Dealership Infrastructure Guidelines are available on the GMDESolutions website at www.gmdesolutions.com. Click Techline IT Solutions > GM IT Standards. (In Canada, look for the GM Techline IT Guidelines in the Service Library under Tools, Processes and Equipment on GlobalConnect.)

The guidelines will be updated on January 1 and the reference to Windows XP Professional for Techline will be removed.

Refer to the guidelines for information on the recommended/required IT infrastructure, hardware and software for the general dealership and service department:

For more information, contact the Techline Customer Support Center at 1-800-828-6860 (English) or 1-800-503-3222 (French).

– Thanks to Lisa Scott

GM Goodwrench Technical Assistance Quality Survey

Changes being made at the U.S. GM Goodwrench Technical Assistance Center (TAC) are evident as soon as a call is made. The automated phone prompt system now requests callers to enter the dealership's six digit BAC code before talking with a TAC representative. Entering the BAC first saves time on the phone because it puts all of the dealership's information immediately at the finger tips of the TAC consultant as soon as the call is answered.

In addition, TAC representatives now request a caller's email address for quality survey purposes. The email address will provide a delivery address should the call be selected to receive the random TAC quality survey. The quality survey provides an opportunity for callers to advise TAC of their satisfaction with the services provided, including technical information and helpful service.

When calling TAC, you are encouraged to give the email address that provides the best way to reach you, whether that is a personal email address or that of the dealership service department. The email addresses are not used for any purposes other than the survey. You will not receive any other communication from GM and the address will not be provided to third parties.

The feedback provided by the quality surveys to TAC is taken very seriously. On your next call, please be sure to provide an email address when requested. It helps TAC find better ways to help you.

– Thanks to Steve Oakley

No Communication with High Speed LAN Modules

A combination of communication conditions may be experienced on the 2010-2011 Camaro. These include intermittent fluctuation of the Instrument Panel (IP) gauges, no crank, Service Engine Soon (SES) light illuminated, various IP warning indicators and messages, and no communication with various High Speed LAN modules.

Communication to the affected control modules may be random and could change during inspection of the vehicle. Any of these conditions could be caused by a short to ground on either of the two High Speed LAN circuits 2500 and/or 2501.

Inspect the engine wiring harness under the Engine Control Module (ECM) for possible chafing on the inner fender panel.

Repair the wiring, install conduit on this area of the harness and relocate the harness away from the panel to protect it from future damage.

– Thanks to Jeremy Richardson

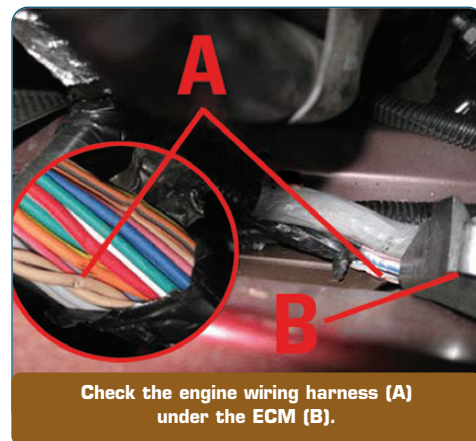

2011 Model Year OnStar No Connection Issues



EL 49903 OnStar antenna test tool and EL 49903-3 adapter

For the 2010 model year, certain vehicles have an antenna diplexer that allows the navigation radio and OnStar to share the same GPS antenna. GM shipped essential tool EL-49903, OnStar antenna test tool, in September 2009 to service all vehicles equipped with OnStar for the 2010 and prior model years.

For the 2011 model year, changes were made to combine the GPS and cell coax connectors into one. GM will release the EL-49903-3 adapter for use with the EL-49903 antenna test tool as an

essential tool in October 2010. In order for the test antenna to be functional with 2011 vehicles, tool EL-49903 must be used. Test tool adapter EL 49903-3 includes EL 49903-4, test coax, and EL 49903-5, combiner.

All 2011 vehicles with OnStar are included, excluding the Regal. The Regal will have an updated OnStar module for vehicles built after August 13, 2010.

The OnStar antenna test tool should be used for conditions where the vehicle is unable to connect to the OnStar call center. The tool will help to isolate the condition to the antenna or the module.

No Connection Diagnostic Procedure

TIP: During diagnosis, proper verification requires the vehicle to be outdoors with an unobstructed view of the southern sky.

The OnStar No Connection Malfunction diagnostic procedure includes:

1. With the ignition Off, disconnect the coax cable connector at the K73 telematics communication interface control (OnStar) module.

2. Connect the EL-49903 with the EL-49903-03 to the K73 telematics communication interface control module; place the test antenna on the roof of the vehicle.
3. Turn the ignition On and contact the OnStar call center consultant by pressing the blue OnStar button. A call center consultant should answer the call, verifying the vehicle OnStar system is functioning. If the OnStar system does not function, replace the K73 telematics communication interface module.
4. With the ignition Off, perform the coax cable test on the coax cable — refer to Component Testing in the Service Information. The coax cable should pass the test. If the coax cable does not pass the test, replace the coax cable.
5. If all circuits test normal, replace the T4 cellular phone and navigation antenna.

– Thanks to Tom Mager

2011 Cruze Passenger Presence System



Here are some tips on the Passenger Presence System (PPS) on the new 2011 Cruze. This system also is used on the G8 and Camaro.

How the System Works

The main function of the PPS is to determine whether to turn the right front passenger airbag on or off, based on the occupant's size and weight.

There are two components that make up the PPS: the module and sensing mat. The module and sensing mat are part of the seat.

The module is mounted under the seat pan and the sensing mat is assembled between the seat foam cushion and seat pan. The sensing mat converts the occupant's size and weight into an electrical signal that the module reads to determine the passenger's classification.

For additional information, a streaming video is available from the U.S. GM Training website, www.gmtraining.com. Click Video on Demand (VOD) on the main menu, and do a key word search for Occupant. The course, 22048.40V – Occupant Safety Systems, will be at the top of the list. Click the VOD link to view the video.

(In Canada, see course 50325.39V – Occupant Safety Systems, at www.gmprocanada.com.)

Parts can be Serviced Separately

Each component (module and/or sensing mat) on this system can be serviced separately.

Please note that there are multiple labor codes, based on each vehicle and part to be returned:

Labor Code	Vehicle	Part
C8868	G8 and Camaro	Sensor
C8869	G8 and Camaro	Module
C8871	Cruze	Sensor
C8869	Cruze	Module

Diagnostic Trouble Codes

The Diagnostic Trouble Code (DTC) information for the PPS can be retrieved with the MDI tool and the Global Diagnostic System (GDS).

Generally, if the PPS has history codes only and no active codes are currently set, there is no need to replace the system. The history codes still need to be cleared using the MDI tool and appropriate electrical tests and visual inspections must be conducted in order to ensure that there is no intermittent problem.

After installing any of the PPS components, the system needs to be rezeroed using the MDI tool. This will update the empty seat reference values stored in the control module and ensure proper system performance.

Following is the proper procedure to rezero the PPS system. After the PPS recognizes the rezeroing command:

1. Ensure that the passenger seat is empty before initiating a rezeroing command. Also check that there are no active DTCs in the PPS.
2. The temperature must be within 32° F to 100° F (0° C to 38° C).
3. With the MDI tool, initiate a rezeroing command.
4. If the system classifies the current seat condition as EMPTY, it will update the reference values.
5. After 20 seconds, cycle the ignition OFF to ON.
6. Verify that the rezero is successful by sitting on the passenger seat and verifying that the passenger air bag indicator light changes from OFF to ON. If the indicator light does not change, follow the SI instructions for DTCs.

A DTC B0081 11 will set to indicate that the rezeroing process has failed.

TIP: If the system fails to rezero, verify the passenger seat is empty and no active DTCs exist. Also, make sure that the temperature is within 32° F to 100° F. Then resend the zero command and follow the instructions above at least three times. During the rezeroing process, the seat must be empty of all objects and the clearance specified in SI must be observed.

– Thanks to Esther Anderson and Sue Rashid

DTC	Description	Possible Root Cause
B0074 00	Flex Mat Sensor Performance	Sensing mat open circuit – Check the sensing mat for damage. If parts replacement is required, replace sensor mat only.
B0074 04	Flex Mat Disconnected	Sensing mat disconnected – Check sensing mat connections. Re-connect sensor mat.
B0081 42	Calibration Not Learned	Seat not rezeroed at seat supplier or dealership – Need to rezero the system.
B0081 11	Rezero Error	Failed rezero – Seat must be empty during rezero. Temperature must be within 32° F to 100° F. – Check the system for DTCs. – Rerun the rezero sequence.
B101D 00	Electronic Control Unit (ECU) Hardware Performance – No additional information required	Check connections – If parts replacement is required, replace ECU only.
B101E 00	Electronic Control Unit (ECU) Hardware Performance – No additional information required	Check connections – If parts replacement is required, replace ECU only.
B101D 3a	Incorrect Component Installed	Check if the correct AOS and SDM components are installed
B1325 03	Battery Voltage Low	Check vehicle battery with IGN on RUN
B1325 07	Battery Voltage High	Check vehicle battery with IGN on RUN
U0140 00	Lost Communications BCM	Check BCM and clear DTC
U0151 00	Lost Communications SDM	Check SDM and clear DTC
U0155 00	Lost Communications IPC	Check IPC and clear DTC

Crankshaft Position Sensor Reluctor

Some 2009-2010 Vibe models equipped with the 1.8L 4 cylinder engine (RPO LAY) may exhibit a crank, no start or hard start condition. DTCs P0012, P0015, P0016, P0017, P0340, or other CMP/CKP-related DTCs may be set in the Powertrain Control Module (PCM).

These conditions may be caused by a damaged reluctor for the CKP sensor. The reluctor is made up of two pieces: the reluctor itself with the teeth around the circumference, and a washer around the center that is welded to the reluctor.

If the welds break, the washer will separate from the reluctor, allowing the reluctor to move on the crankshaft and cause the driveability concerns. Although both the reluctor and washer are keyed, the reluctor relies on the washer to keep it stationary. Check for this condition only when the related CMP/CKP sensor DTCs are set.

A loose reluctor may be confirmed through the CKP sensor hole. If this condition is found, replace the CKP sensor reluctor.

– Thanks to John Kopeck



Electronic Brake Control Module Communication

On some 2008-2011 Enclave; 2007-2011 Escalade, Escalade ESV, Escalade EXT, Avalanche, Silverado, Suburban, Tahoe, Acadia, Sierra, Yukon, Yukon XL, Yukon Denali, Yukon Denali XL; 2009 XLR; 2010-2011 Camaro; 2009-2011 Corvette, Traverse; 2008-2009 G8; and 2007-2010 OUTLOOK models, with StabiliTrak (JL4), the ABS MIL and red Brake MIL may be illuminated on the instrument cluster.

When trying to retrieve DTCs for this condition, the scan tool will not communicate with the Electronic Brake Control Module (EBCM), but will communicate with all other high and low speed GM LAN modules. Some modules may have set a DTC U0121 against the EBCM.

During diagnostics, the power circuits, ground circuits, communication enable signal circuit, and GM LAN circuits going to the EBCM may test OK, which may lead to replacement of the EBCM. However, the condition may still be present after installing the new EBCM.

This condition may be caused by shorted yaw rate and lateral acceleration sensor supply voltage (circuit 2087, dark green) pulling down the internal circuitry of the EBCM. If circuit 2087 is backed out of the EBCM connector and communication returns, inspect for this circuit shorted to ground or a yaw sensor concern.

On some full-size utility vehicles, the circuit may be shorted under the passenger front seat at the rear camera module bracket.

Repair the circuit as necessary and reroute to prevent the condition from reoccurring.

– Thanks to Ron Erman

Intermittent Low Power after Turbo Upgrade Kit Installation

On the 2008-2010 Cobalt SS and HHR SS equipped with the 2.0L turbocharged 4-cylinder engine (RPO LNF) and the turbo upgrade kit installed (p/n 19212670), an intermittent low power condition may be experienced. There are typically no DTCs present with this condition. However, possible DTCs that may set include P0236, P2166 and P2261. The Service Engine Soon (SES) light also may be illuminated.

Vehicle owners may state it feels like the engine has very little acceleration or the engine rev limiter is engaging. In some cases, the vehicle may accelerate up to approximately 80-90 MPH before the condition occurs.

TIP: This information does not apply to vehicles that have not had the turbo upgrade kit installed.

Installation of the turbo upgrade kit for these vehicles requires both MAP sensors to be swapped for Bosch TMAP

sensors. The lower sensor, located on the Charge Air Cooler (CAC) pipe, is hard to reach and can be difficult to install. When installing these new sensors, the existing wiring must be cut and new wiring crimped to a new connector.

The low power condition may result from the front lower TMAP sensor (on the charge air cooler pipe) wiring rubbing and chafing against the A/C compressor or line.

A poorly sealed or improperly installed heat sealed splice sleeve on the TMAP sensor wiring also may cause this condition. Any corrosion inside the splice sleeve or at the connector may lead to an intermittent or high resistance connection and the potential for a low power condition.

The lower TMAP sensor is hard to reach and it can be difficult to inspect the wiring for damage. It may help to review the following SI information: Engine > Engine Controls and Fuel - 2.0L > Repair Instructions > Intake Air Pressure and

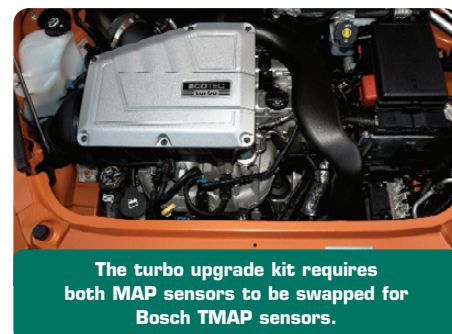

Temperature Sensor Replacement as well as Charge Air Cooler Outlet Pipe Replacement. These documents may help provide additional instructions on how to access the TMAP sensor and wiring for inspection.

Also check the TMAP sensor values using a scan tool while checking the wiring. Any difference in the values may affect engine performance.

Flexible tubing (protective plastic sleeve) can be installed around the harness to help prevent any future harness.

– Thanks to John Kopeck

High Strength Steel Drill Bits

A number of high strength steels are used in GM vehicles to help improve safety, fuel economy and performance. These high strength steels are located in a variety of locations on GM vehicles, such as rocker reinforcements and structural components. In order to repair structural or collision damage, it's often necessary to drill out the resistance spot welds to separate the components being repaired from the vehicle structure.

To remove these spot welds, there are various drill bits available; however, the useful life of many of these drill bits is limited by the hardness of the high strength steels.

The GM Collision Repair Technology Center has recently validated a CryoCobalt™ drill bit that has been developed for use with very hard metals. These drill bits should allow for increased production and reduced overall cost related to resistance spot weld removal.

The CryoCobalt drill bits feature:

- CM-88™ chrome moly cobalt high heat steel
- Heat resistance up to 1,200° F (650° C)
- Hardness of 66-68 Rc
- 135° split point tip design
- Patented thermal cycling cryogenic treatment for extended life

The CryoCobalt drill bits have increased microsharpness for use on hardened, high strength alloy steels along with a thicker web that withstands the higher feed pressure required for drilling



The new Cruze offers excellent safety protection with the use of high strength low alloy steel, mild steel, dual phase steel and ultra high strength dual phase steel throughout its structure.

harder metals, helping to reduce breakage.

The drill bits also can be re-sharpened. It's recommended to use a drill sharpening machine to help maintain the split point.

Refer to Bulletin #10-08-98-002 for part numbers and ordering information. The drill bits listed are available directly from the manufacturer with special GM pricing.

– Thanks to Gary Kirrkamm



CryoCobalt: drill bits



CryoCobalt Drill Bit Index 1/16" to 1/2"

Engine Misfires

An illuminated Service Engine Soon (SES) light and an engine misfire condition on some 2010-2011 CTS-V, Escalade, Avalanche, Camaro SS, Colorado, Corvette, Express, Silverado, Suburban, Tahoe, Canyon, Sierra, Savana, and Yukon models equipped with a V8 Engine (RPOs L20, L94, L96, L99, L9H, LC9, LH9, LMF, LMG, LSA, LS3, LS7, LS9, LY6, LZ1) may be caused by a loose spark plug wire at the ignition coil.

Any of the following DTCs may be present: P0300, P0301, P0302, P0303, P0304, P0305, P0306, P0307, P0308.

Inspect the spark plug wire of the cylinder with current and/or history misfires. If the spark plug wire is obviously loose at the ignition coil end, replace the related spark plug wire and re-evaluate the condition.

– Thanks to James Parkhurst

Two-Mode Hybrid Internal Transmission Wiring Harness Repairs

On the 2008-2011 Tahoe and Yukon, and 2009-2011 Escalade, Silverado and Sierra, equipped with the Two-Mode Hybrid Option (RPO HP2), diagnostics of any of the following DTCs may lead to an internal transmission wiring harness concern:

P0A2B, P0A2D, P0AA31, P0A32, P0A33, P0A2C, P0A3F, P1B03, P0A40, P0A45, P0C61, P0A46, P0C52, P0C5C, P0C57, P1B04, P181C, P181D, P181E, P181F, P183A, P183B, P183C, P183D, P183E, P183F, P184A, P184B.

If the internal transmission wiring harness is found to be the root cause of any of these DTCs, DO NOT attempt to repair the wiring harness. The internal transmission wiring harness must be replaced if it is found to be causing the condition.

– Thanks to Charles Krepp

GM TechLink is a monthly magazine for all GM retail technicians and service consultants providing timely information to help increase knowledge about GM products and improve the performance of the service department.

Publisher:

Thomas J. Arnold
GM Customer Care and Aftersales
 Thomas.Arnold@GM.com

Editor:

Lisa G. Scott
GM Customer Care and Aftersales
 Lisa.G.Scott@GM.com

Technical Editor:

Mark Spencer
 mspencer@gpworldwide.com

Production Manager:

Marie Meredith

Desktop Publishing:

5by5 Design LLC
 dkelly@5by5dzn.com

FAX number: 

1-248-729-4704

Write to: 

TechLink
PO Box 500
Troy, MI 48007-0500

GM TechLink on the Web: 

GM GlobalConnect

General Motors service tips are intended for use by professional technicians, not a "do-it-yourselfer." They are written to inform those technicians of conditions that may occur on some vehicles, or to provide information that could assist in the proper service of a vehicle. Properly trained technicians have the equipment, tools, safety instructions and know-how to do a job properly and safely. If a condition is described, do not assume that the bulletin applies to your vehicle or that your vehicle will have that condition. See a General Motors dealer servicing your brand of General Motors vehicle for information on whether your vehicle may benefit from the information.

Inclusion in this publication is not necessarily an endorsement of the individual or the company.

Copyright© 2010 General Motors Company
All rights reserved.

Tail Pipe Depressions

When inspecting the exhaust system of the 2007-2010 Silverado and Sierra Crew and Extended Cab models with the 6' 6" box and 6.6L diesel engine (RPO LMM), depressions in the tail pipe may

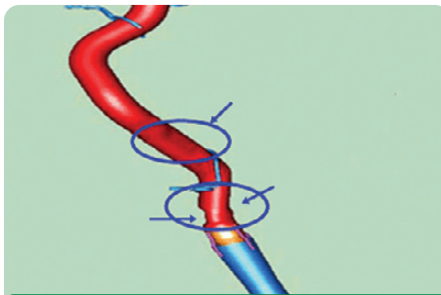

Location of depressions in the tail pipe.

be noticed. These depressions are design-intent and are purposely created to provide production tooling clearance during the assembly of the vehicle.

If the exhaust system is being inspected during diagnosis of an engine performance concern, do not replace the muffler/tail pipe assembly due to these depressions. The depressions have minimal impact on the overall exhaust system back pressure and have no effect on fuel economy or performance.

The service tail pipe assembly, which does not have the depressions, does not offer an advantage or benefit over the production tail pipe assembly with the depressions.

– Thanks to Jim Will

Two-Mode Hybrid Pickups Cargo Box Noise

The 2009-2011 Silverado Two-Mode Hybrid and Sierra Two-Mode Hybrid with the soft tonneau cover (RPO VPB) may have a rattle, clicking, or knocking noise coming from the rear of the cab while driving with the soft tonneau cover in the closed position.

The rattle or knocking noise may be the result of the plastic buckles on the tonneau cover contacting the cargo box or cab due to not being properly stowed. The tonneau cover features elastic cords that should be used to properly secure the buckles.

Check to make sure the tonneau cover buckles, located at the front of the cargo box, are properly secured.

– Thanks to James Will

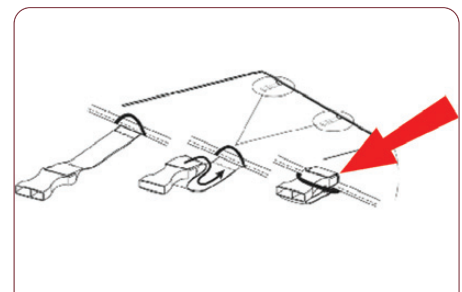

Use the elastic cords to secure the buckles at the front of the cargo box.

Radio Display Fogging

Portions of the radio display on the 2010-2011 Camaro may fog when using the air conditioning. This will typically occur when the fan speed is set to High and the center vents are pointed down toward the radio display.

This is an environmental condition induced by blowing cold air across a warm display, similar to condensation forming on a cup of ice water. This condition can be reduced or eliminated by not pointing the center instrument panel HVAC vents down toward the radio. In addition, once the vehicle interior has cooled off, it is suggested to decrease the fan speed.

– Thanks to Jeremy Richardson



Do not point the center vents down to help avoid radio display fogging.



Car Issues – Fix It Right the First Time

Model Year(s)	Vehicle Line(s)/ Condition	Do This	Don't Do This	Reference Information / Bulletin
2011	Regal -- Noise from rear of vehicle when driving over rough road surfaces	Inspect tail lamps and install foam isolation material	Don't repair other areas prior to inspecting the tail lamps	PI0216
2011	Regal -- Incorrect SPID label for RPO AUA	Disregard RPO AUA on vehicles built prior to August 1, 2010	Don't order parts based on RPO AUA for vehicles built prior to August 1, 2010	10-00-89-015
2007-2011	Enclave, Escalade, Escalade ESV, Escalade EXT, CTS, CTS-V, CTS Sport Wagon, SRX, Avalanche, Silverado, Suburban, Tahoe, Malibu, Traverse, Equinox, Acadia, Sierra, Yukon, Yukon XL, Yukon Denali, Yukon Denali XL, Terrain, G6, AURA, OUTLOOK – Low beam headlamp bulb	Inspect the connector and, if necessary, repair connector and replace bulb	Don't replace the entire headlamp assembly	10-08-42-001A
2010-2011	Aveo -- Wiper blade protector application to prevent wind noise	Remove the wiper blade protector	Don't deliver the vehicle with the protector still in place	10-00-89-013
2006-2010	Cobalt, G5 -- SIR light illuminated, DTC B0081 and PPS code 23 stored	Diagnose and replace the anchor pretensioner	Don't replace the PPS	09-09-40-003A
2007-2010	HHR -- Driver and/or passenger seat concerns with armrest comfort	Educate the customer and adjust seat angle	Don't replace the armrest	10-08-50-007
2006-2010	Lucerne; DTS; Escalade; Escalade ESV; Escalade EXT; SRX; CTS; CTS Wagon; Camaro; Monte Carlo; Impala; Equinox; Avalanche; Silverado; Suburban; Tahoe; Express; Traverse; Acadia; Sierra; Yukon; Yukon XL; Yukon Denali; Yukon Denali XL; Savana; Terrain; Torrent; G8; H2; OUTLOOK; VUE -- Unable to Reprogram BCM	Reprogram the module with the revised process	Don't replace the module and program	09-08-47-001A
2000-2011	All -- Information on Tire Radial Force Variation (RFV)	Use the steering wheel shake worksheet	Don't replace parts or tires without determining the source for a smooth road shake	00-03-10-006F



Truck Issues – Fix It Right the First Time

Model Year(s)	Vehicle Line(s)/ Condition	Do This	Don't Do This	Reference Information / Bulletin
2009-2011	Avalanche; Escalade; Escalade ESV; Escalade EXT; Sierra; Silverado; Suburban; Tahoe; Yukon; Yukon Denali; Yukon XL; Yukon XL Denali -- Exhaust leak and/or noise	Install new clamp and align exhaust	Don't replace the muffler and pipe assembly	10-06-05-003
2007-2010	Allure; Avalanche; Camaro; Envoy; Escalade; G8; Grand Prix; Impala; LaCrosse; Monte Carlo; Rainier; SAAB 9-7x; Sierra; Silverado; Suburban; Tahoe; TrailBlazer; Yukon -- AFM engine, valve lifter tick noise at start up	Verify the start up engine tick after sitting for 2 + hours does stop after a period of operation- replace all lifters AFM and non- AFM	Don't replace other internal mechanical parts for start-up tick noise	10-06-01-007
2008-2010	Canyon; Colorado -- Pickup bedliner noise	Install the bedliner repair service kit	Don't replace or modify the truck's bedliner	PI0204
2010	Equinox, Terrain -- Rattle noise from front of engine at idle	Replace the balance shaft chain and tensioner	Don't replace the A/C compressor or the timing chain tensioner.	PI0202
2010-2011	Equinox; Terrain -- Front suspension or front strut noise	Apply grease around the circumference of the strut shaft that is exposed	Don't replace any front suspension components	10-03-08-003
2002-2011	Avalanche; Escalade EXT -- Tonneau cover water leak	Adjust strikers for seal compression	Don't replace the cargo cover or seals	07-08-57-005A

Service Know-How

10210.10D Emerging Issues | October 14, 2010

To view Emerging Issues seminars:

Log in to www.gmtraining.com, select Service Know-How/TECHAssist from the menu, select Emerging Issues, and then Searchable Streaming Video to choose the current Emerging Issues seminar or past programs.