



## Remote Keyless Entry Interference

The GM Remote Keyless Entry (RKE) systems operate on high frequency radio signals. Therefore, they may be subject to radio signal interference — ranging from radio towers to department store automatic sliding doors — that will affect RKE operation. If an RKE system receives two transmissions from separate sources at the same time, it will ignore both.

During diagnosis of an RKE system with a reduced or intermittent range condition, first determine if the root cause lies with the transmitter (key fob), the receiver (in most cases, the Remote Control Door Lock Receiver) in the vehicle, or is the result of radio frequency (RF) interference.

With every button press on the transmitter, the RKE system works in conjunction with the Body Control Module (BCM) to remotely activate certain vehicle features. This is accomplished by the transmitter sending a radio frequency signal to the Remote Control Door Lock Receiver (RCDLR), which interprets the signal and activates the requested function via a serial data message to the BCM.

**TIP:** To prevent transmitter battery drain on later models, any RKE transmitter button(s) that is depressed longer than 30 seconds or pressed multiple times will be disabled. The disabled button(s) will remain disabled until another button that has not been disabled is pressed or if the disabled button(s) is not used for a certain amount of time.

Begin any diagnosis by first verifying that the transmitter part number is the correct model for the vehicle. There may be several transmitters used in the owner's household. The incorrect



continued on page 2

### TECHLINE news

## Vibe Powertrain Control Module Programming

Additional Powertrain Control Module (PCM) calibrations have recently been released for the Pontiac Vibe that address various drivability and illuminated MIL issues. For dealerships that do not have extensive experience servicing the Vibe, it has a unique service programming process that requires the use of the Calibration Update Wizard (CUW) application; the Service Programming System (SPS) is not used. The CUW application is a separate application that is downloaded from TIS2Web.

To download the application:

- Click the Help menu question mark icon on the TIS2Web homepage
- Click Vibe Programming Application and Calibrations in the left column of the Help screen
- Two separate options are available – Download the Vibe Programming Application, and Vibe Programming Application and Calibrations

continued on page 2

### GM TECH *Link*

#### Contents

Remote Keyless Entry Interference . . . . .	1
Vibe Powertrain Control Module Programming . . . . .	1
Hybrid Battery MIL Illuminated/ No Charge Condition . . . . .	3
Duramax Diesel Turbocharger Vane Position Sensor . . . . .	3
Volt Power Mode Methods . . . . .	4
Rear Seat Belt Reminder Indicator Operation . . . . .	4
Jump Starting the Volt . . . . .	5
Bleeding the Brakes . . . . .	5
Battery Too Cold Message . . . . .	5
Intermittent Service Stability/Traction Control Messages . . . . .	6
New HD Trucks' Steering System . . . . .	6
Detonation/Spark Knock under Light Acceleration . . . . .	7
Sunroof/Sunshade Relearn Tips . . . . .	7
Service Know-How . . . . .	7
Car Issues – Fix It Right the First Time . . . . .	8
Truck Issues – Fix It Right the First Time . . . . .	9



# Remote Keyless Entry Interference — continued from page 1

transmitter may pass the testing procedure, but it will not activate the RKE system.

## Interference

As the number of electronic devices incorporated or carried in vehicles increases, so does the chance of interference and concerns of poor RKE system performance. Devices that may cause interference with the RKE system include common items such as cell phone cords plugged into power outlets without the phone present, wireless doorbell transmitters, and garage door openers.

Typical sources of interference that may result in reduced RKE transmitter operation include:

- Proximity to radio towers, airports, police and fire towers
- Installation of some aftermarket accessories
- The presence of fluorescent lighting
- Some brands of radar detectors, CB radios, walkie-talkies, mobile radios, and cell phone chargers. These devices may be in the affected vehicle or may be in another vehicle in close proximity
- High RF traffic areas, such as shopping malls or stores with automatic doors or other RF devices
- Line of sight; the transmitter signal may simply be obstructed by another vehicle, a building or other obstructions

Since some sources of interference are based on location, be sure to ask the cus-



J 43241 Keyless Entry Tester

tom if the RKE transmitter operates intermittently or erratically in only certain locations. Ask if these locations are near radio towers, airports or other common RF sources.

## Keyless Entry Tester

If a customer comments that the remote transmitter fails to operate, press each button on the transmitter one at a time while observing the vehicle systems to verify operation.

If interference is suspected, it may be possible to locate devices transmitting unwanted signals using the J 43241 Keyless Entry Tester. Since the unwanted transmissions are the same frequency as the key fob, the LED on the tester will light when the tester is slowly swept near the device. Be sure to sweep around all storage areas in the vehicle and under the instrument panel and seats.

Also use the J 43241 tester to test the functionality of each button on the transmitter. The tester should sound a tone and illuminate the green LED when each transmitter button is pressed. If a button fails, replace the transmitter battery and test the transmitter again before replacing it.

**TIP:** For many 2006 and later vehicles, some functions require more than one short button press. Activating the trunk release, for example, requires pressing and holding the transmitter button before the trunk lid will release.

If the transmitter is functioning properly, program the RKE system following the procedures in the appropriate Service Information. All transmitters for the vehicle must be present when programming the system.

The RKE transmitter commands can be viewed on many vehicles using a scan tool.

## Resynchronization

Finally, a weak transmitter or vehicle battery also could lead to reduced RKE system operation. It may be necessary to resynchronize the transmitter with the vehicle if the transmitter batteries are replaced.

If only the fuel door button (some Cadillac models) or the panic button (all other models) works, this may be a sign that the system needs to be resynchronized. Follow the transmitter synchronizer procedure in the appropriate Service Information.

🙏 Thanks to Ron Asmar and Brian Combs

## TECHLINE news

continued from page 1

# Vibe Powertrain Control Module Programming

For complete download instructions, refer to Bulletin #09-06-04-006A.

**TIP:** The CUW application does not contain any calibrations. Calibrations must be downloaded separately from TIS2Web after the programming application has been installed on the shop PC.

When reviewing available calibrations, follow the table to ensure the correct calibration is selected for the condition



and model year.

While performing service on the Vibe, it is necessary to use both the Tech 2 and the Multiple Diagnostic Interface (MDI). The Tech 2 is used for retrieving the PCM calibration and for performing the VIN learn function. The MDI is used for programming.

🙏 Thanks to Mike Waszczenko



# Hybrid Battery MIL Illuminated/No Charge Condition

Some 2008-2010 Malibu Hybrid models and 2007-2009 AURA Hybrid and VUE Hybrid models may have an illuminated battery MIL or a no charge condition with DTCs P0AF8 (Hybrid System Voltage) or P0AFB (Hybrid Battery System Voltage High) set. The DTCs may have set after servicing the Hybrid Battery Pack.

Follow all published Service Information (SI) diagnostics if DTC P0AF8 or P0AFB are set. If there are other DTCs present along with DTC P0AF8 or P0AFB, diagnose those DTCs before continuing with the P0AF8 or P0AFB diagnosis. If diagnosis leads to Testing for Intermittent Conditions due to a history DTC P0AF8 or P0AFB, or if it leads to Starter Generator Control Module (SGCM) replacement due to a current DTC P0AF8 or P0AFB, perform the following procedures before considering SGCM replacement.

Disconnect the hybrid battery by following the Hybrid Battery Service Disconnect/Connect Procedure in the Service Information.

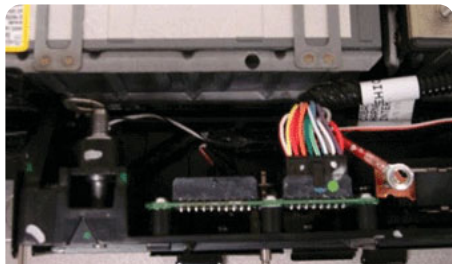

**If a DTC P0AF8 or P0AFB is setting, the connections at the BECM, contactor relay and disconnect switch should be checked.**

- Check that the disconnect door fastener is tight so the disconnect switch does not open and close. If the fastener is loose, or if you hear the switch open and close while

wiggling the door, it could be causing this condition. Open and close the door while listening to the disconnect switch, you should hear it open and close each time that the door is opened and closed. If OK, follow with the rest of the disconnect procedure before proceeding.

Disconnect and inspect all of the connection points, following the SI procedures, called out in the following illustrations for signs of arcing, corrosion, etc.

- If a DTC P0AF8 or P0AFB is setting, the connections at the BECM, contactor relay and disconnect switch should be checked.

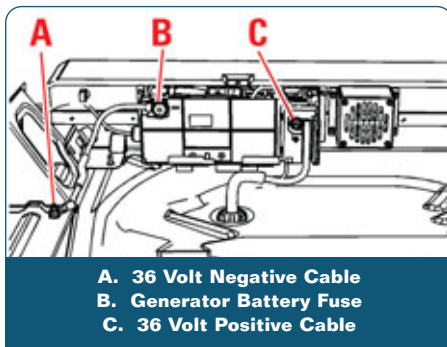

**A. 36 Volt Negative Cable  
B. Generator Battery Fuse  
C. 36 Volt Positive Cable**

Also check the following connections:

- 36 volt negative cable
- Generator battery fuse
- 36 volt positive cable
- 36 volt positive cable at generator control module
- Ground strap at generator control module and chassis connection generator control module connectors
- If any sign of arcing or corrosion is noticed on a ring-terminal, replace the related cable. If no sign of arcing is noted,

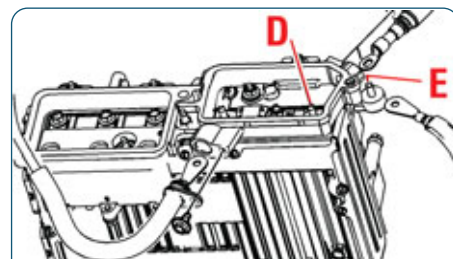

**D. 36 Volt Positive Cable at Generator Control Module  
E. Ground Strap at Generator Control Module and Chassis Connection Generator Control Module Connectors.**

clean all ring-terminal connection points with a wire brush.

- Apply a light coat of dielectric grease to all of the disassembled ring-terminal connection points above and to the terminals of the SGCM connectors. Refer to Bulletin #09-06-03-004 for the grease part number.
- Follow SI procedures to reassemble. It is very important to use the SI torque specifications when reassembling the ring-terminal connections.
- Reconnect the hybrid battery and reinstall the battery cover, making sure it clicks — indicating it contacts the disconnect switch. Re-evaluate the condition.

If DTC P0AF8 or P0AFB resets immediately, check the Hybrid Battery Pack voltage levels on the Battery Energy Control Module (BECM) and SGCM data lists and refer to DTC P0AF8 or P0AFB diagnostics in SI. If all voltage levels check appropriately, replace the BECM. If the DTCs reset and the above tests have been performed again, the SGCM should then be replaced.

☺ Thanks to Brian Ciaverella

# Duramax Diesel Turbocharger Vane Position Sensor

The turbocharged 6.6L Duramax diesel engine (RPO LGH, LML) is available in several Express, Silverado, Savana and Sierra models.

## Updated Vane Position Sensor

On some 2010-2011 Express, Silverado, Savana and Sierra models equipped with the Duramax diesel (RPO LHG, LML), an intermittent turbocharger Vane Position Sensor (VPS) DTC may set. To address this condition, an updated VPS

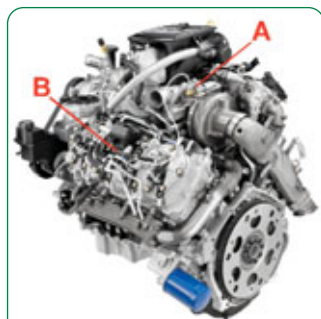

**A. Vane Position Sensor  
B. Electrical connector/module**

is available that interfaces with the ECM more efficiently.

Complete the appropriate Service Information (SI) diagnostic procedures for any set DTCs. If DTC P2564 or P2565 is stored along with an intermittent Service Engine Soon light, also inspect the VPS serial number located on the electrical connector/module.

An updated VPS will have a serial number of -0011 or higher. If the VPS has a serial number ending in -0010, the sensor will need to be replaced.

☺ Thanks to Donald Langer



**The serial number is located on the electrical connector/module.**

# Volt Power Mode Methods

The Volt uses three unique power mode methods: Vehicle Off, Vehicle On, and Vehicle in Service Mode. When performing service, it's important to know the operation of each power mode method.



**Vehicle Off:** This mode provides no electrical power to the vehicle. The Power button will not be illuminated.

**Vehicle On:** This mode places the vehicle in a propulsion active state. This is uniquely different than other push button start vehicles in that it is the equivalent of not only powering up the electrical system, but also starting the engine/electric drive system.

To place the vehicle in the Vehicle On mode, press the Power button once while the brake pedal is applied. The Power button will illuminate steady. If the vehicle is being serviced using Vehicle On mode, it is recommended that the parking brake be engaged to prevent any unwanted movement of the vehicle.

**TIP:** In the Vehicle On mode, the engine will start if the hood is open. Take precautions when stringing wires and using testing tools under the hood of the vehicle before entering Vehicle On mode.

**Vehicle in Service:** This mode provides electrical power to the

vehicle but the propulsion mode is inactive. Some systems may be inactive in Vehicle in Service mode. To place the vehicle in the Vehicle in Service mode, press and hold the Power button for five seconds. The Power button will illuminate steady.

It is important to become familiar with the Volt description and operation section of Power Moding in the Service Information before performing service on a Volt. The diagnostics for the Volt call out a specific power mode for many sections or DTC diagnostics. Using the wrong mode may lead to an inaccurate diagnosis. Most programming events require the vehicle to be in the Vehicle in Service mode active state.

Power Mode Methods	
Power Mode Parameters	Resulting Power Mode
In Vehicle Off power mode, then press the Power button with the Brake pedal depressed; transmitter in vehicle	Vehicle On
In Vehicle Off power mode, then press and hold the Power button for more than 5 seconds without the brake pedal depressed; transmitter in vehicle	Vehicle in Service Mode
In Vehicle On power mode, then press the Power button with or without brake pedal depressed; transmitter in vehicle	Vehicle Off

🙏 Thanks to Dennis Richey

# Rear Seat Belt Reminder Indicator Operation

The 2011 Volt is equipped with a rear seat belt reminder (RSBR) indicator that notifies the driver about the status of the rear seat belts. There may be some confusion about how long the indicator is illuminated in the instrument cluster.

For rear seating, occupancy is determined strictly based on the seat belt switches; occupant sensing mats are not used. Rear seat occupants are not detected until the seat belt is buckled. If rear seat occupants never buckle the seat belts, the system will not detect their presence. If the occupants do buckle the seat belts, the occupants are

detected and each corresponding seat belt reminder indicator will illuminate green.

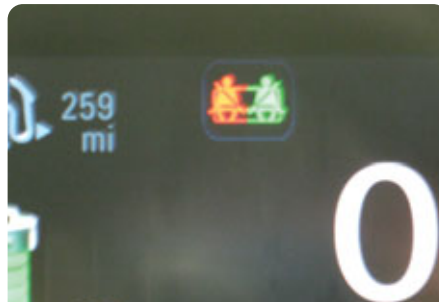

In this example, the indicator shows that the right-side seat belt is buckled and the left-side seat belt is unbuckled.

The indicator has two sections to specify which seatbelts are buckled. If a seatbelt is unbuckled, the indicator will be red, and if the seatbelt is buckled, the indicator will be green.

The rear seat belt indicator is designed to stay on until the vehicle speed exceeds 6.5 mph (10 km/h) for 35 seconds whether the rear seat belts are buckled or unbuckled. If the vehicle is driven over 6.5 mph (10 km/h) before reaching 35 seconds and

then stops again, the timer resets and the vehicle must be driven over 6.5 mph (10 km/h) until the 35 second timer is reached.

Once a rear seat occupant is detected, the system will assume that occupant is present for the duration of the ignition cycle or until a rear door opens. If a rear door is opened or an ignition cycle occurs, the indicator will reset and assume there are no rear occupants until a buckle is latched again.

If a rear seat occupant unbuckles during the same ignition cycle and the vehicle speed exceeds 6.5 mph (10 km/h) for 35 seconds, the rear seat belt indicator will illuminate red in full screen mode and the rear seat belt reminder chime will sound. The chime will stop after three seconds, but the rear seat belt reminder indicator will remain illuminated until the occupant buckles or the ignition cycle ends. If the occupant rebuckles, the indicator will illuminate green and will not go out until the speed and time criteria is met again.

🙏 Thanks to Paul Radzwillowicz



The rear seat belt indicator is in the center of the instrument cluster.

# Jump Starting the Volt

The 12-volt battery on the 2011 Volt is located below the cargo floor in the rear hatch. When attempting to jump start a dead 12V battery, use the remote 12V terminals located under the hood on the driver's side of the vehicle. The positive terminal is under an access cover. The negative terminal is marked GND. These terminals should be used for jump starting because the rear hatch is inaccessible with a dead 12V battery.

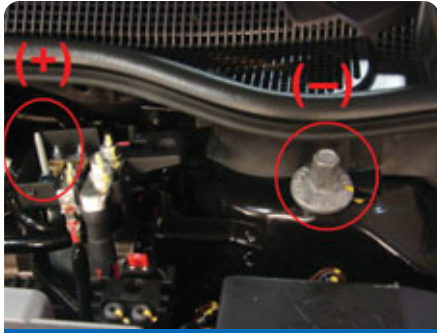

Use the remote 12V terminals under the hood when jump starting the Volt.

**TIP:** Do not try to jump start another

vehicle using the remote 12V terminals. If the remote 12V terminals are used to jump start another vehicle, the in-line safety fuse will open to protect the Volt electrical system. When attempting to jump start a vehicle with the Volt, connect the jumper cables directly to the 12V battery terminals located in the rear hatch.

When jump starting the Volt, after the proper jumper cable connections are made, press the Power button while the brake pedal is applied to start the Volt. This will wake up the electronics on the Volt. After the instrument cluster initializes, and the vehicle enters propulsion mode, power from the high voltage battery will be used to charge the 12V battery.

The high voltage battery of the Volt cannot be jump started either with another vehicle or a battery charger.

🙏 Thanks to Ashmi Haria

# Bleeding the Brakes

The 2011 Volt braking system is unlike most traditional hydraulic brake systems. It is very important for proper brake system performance to follow the brake bleeding procedure exactly. Air trapped in the brake system will cause performance problems and set DTCs without the symptoms of a spongy or low brake pedal. If a step is missed in the brake bleeding procedure, the process must be started over at step 1 without exception.

- Install a battery charger on the vehicle to maintain battery voltage.
- Use a pressure bleeder that is capable of delivering 30 psi for the entire bleeding procedure. Failure to provide a constant 30 psi will cause air to be trapped in the brake system and may cause brake performance problems or DTCs to set. Tool J 29532-A, Brake Pressure Bleeder, has been tested extensively on this application and has proven to provide the necessary pressure and volume of brake fluid.

**TIP:** Vacuum bleeding and other brake bleeding tools are not acceptable for the brake bleeding procedure.

A J 29532-A brake pressure bleeder or a diaphragm-type (ball bleeder) pressure bleeder along with the J 35589-A, Brake Pressure Bleeder Adapter, must be used in order to perform the hybrid brake system bleeding procedure. A replacement J 29532-A can be ordered from 1-800-GM-TOOLS.

**TIP:** Do not attempt to use the manual bleeding procedure as this will not properly bleed all the air from the system.

🙏 Thanks to Paul Radzwilowicz



J 29532-A Brake Pressure Bleeder

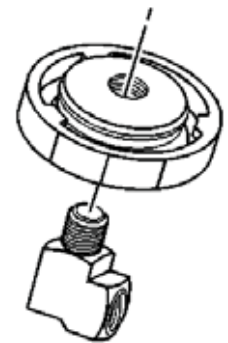

J 35589-A, Brake Pressure Bleeder Adapter

# Battery Too Cold Message

If the Battery Too Cold, Plug In to Warm message is displayed on the Driver Information Center of the 2011 Volt, the vehicle will not start until the high voltage battery is warmed up.

This condition usually occurs on vehicles that have been parked for a prolonged period of time in extremely cold temperatures (approximately -14°F or -25°C)

When the vehicle is subjected to cold temperatures for an extended length of time, the electrolyte in the high voltage battery cells starts to freeze. Once this occurs, current cannot pass through the battery for any reason, such as starting the gasoline engine or powering the battery internal heater. It is a physical limitation

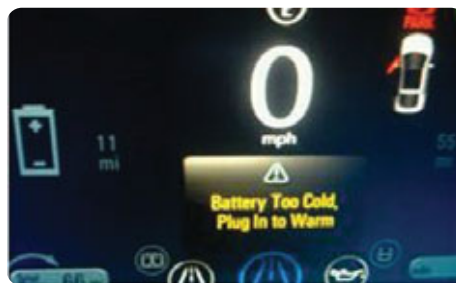

much the same as diesel fuel gelling at very cold temperatures and making the vehicle impossible to start.

If this condition occurs, advise the customer of the physical limitations of the high voltage battery and that this is a normal condition. Plug in the vehicle to allow the

charging system to warm the high voltage battery, and then the vehicle can be started.

Without a charger to provide power from somewhere besides the high voltage battery, the contactors cannot be closed and the vehicle cannot be started. The Volt does not have a conventional 12V starter and needs the high voltage battery to supply voltage to the electric motor to start the gasoline engine.

**TIP:** Keep the Volt plugged in when possible, even when fully charged, to keep the battery temperature ready for the next drive.

🙏 Thanks to Paul Radzwilowicz

# Intermittent Service Stability/ Traction Control Messages

Intermittent Service StabiliTrak, Service Traction Control, or Service All Wheel Drive messages may be displayed on the Driver Information Center of some 2010-2011 Equinox and Terrain models. Any combination of the following DTCs also may be set: C0186, C0196, C0710, U0125, U0126, U1826, and U1827.

DTC U0125 (Lost Communication with Multi-Axis Acceleration Sensor Module) may be set along with DTCs C0186 and/or C0196. Another example may be DTC U0126 (Lost Communication with Steering Wheel Angle Sensor Module) set along with DTC C0710. On all-wheel drive models, DTC U1826 (Lost Communication with Multi-Axis Acceleration Sensor Module on Bus B) or U1827 (Lost Communication with Steering Angle Sensor Module on Bus B) may be set

in the Rear Differential Control Module.

If a condition is not identified after following the Service Information diagnostics for the set DTCs, check the J307 splice for circuit 2087 (D-GN wire) for corrosion or partially broken wire strands at the splice crimp. Upon inspection the wire may easily break off when moving the harness. Complete the wire repair and clear the DTCs.

🙏 Thanks to Gordon Baillo



Check the J307 splice for circuit 2087 D-GN wire.

## New HD Trucks' Steering System

The steering system of the new 2011 Silverado and Sierra 2500 and 3500 HD trucks is designed to support the trucks' greater front gross axle weight rating. The diagnosis of any steering conditions on the new HD trucks can be aided by a better understanding of this revised system. Although the steering systems of the 2011 and 2010 model years look similar physically, there are several differences.

### Steering Dampener Shock

The 2011 HD trucks are built without a steering dampener. Although the 2010 MY steering dampener shock will fit into a 2011 MY vehicle, the shock itself is too short and will impede correct movement of the steering system on the 2011 MY vehicles.

Regarding road input, the steering dampener's predominate influence is on large, heavy impacts encountered during more extreme off road events. For smaller chatter/bump surfaces, the steering dampener does not see high enough rod velocity to generate resistance force. For these situations, there is more mounting bushing compression.

The 2011 HD trucks' steering gear system features the same generic knuckle steering arm to pitman arm length ratio as the 2010 and previous HDs, but the steering gear piston diameter is larger and capable of higher pressure, which creates more viscous damping in the 2011 HD steering gear than the 2010 and previous steering gears.

Installing a 2010 MY steering dampener on a 2011 MY vehicle can cause a sticky on-center feel and may contribute to steering returnability issues where there would be little to no returnability. In which case, the

driver would need to apply near continuous effort to pull the steering wheel back to center. A 2010 MY steering dampener should not be installed on a 2011 HD 2500/3500 truck.

### Steering Stabilizer

The 2011 HD trucks also do not have a steering stabilizer.

A steering stabilizer is available in the parts catalog, but it is not intended to address conditions such as steering wheel vibration or brake pulsation. A steering stabilizer can be installed, but is not intended to be used for a warranty repair.

### Steering Gear Box Mounting Pad

At the start of production of the 2011 Silverado 2500 and 3500 and Sierra 2500 and 3500, a shim was released for the upper steering gear box mounting location.

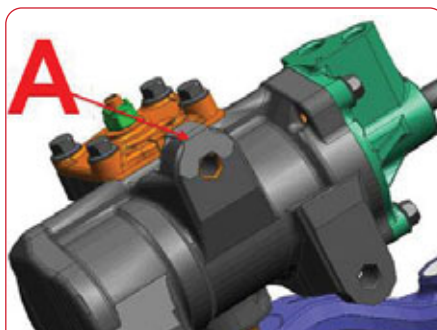

A shim (A) is used on early production steering gear box mounting locations.

The shim is used only on early production gears that do not have the under cuts. Later production gears had under cuts made to their mounting locations and the shim is not needed.

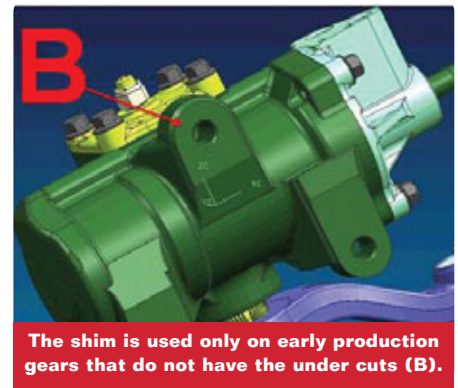

The shim is used only on early production gears that do not have the under cuts (B).

When replacing a steering gear box, determine if a shim will be needed on the replacement part. If a shim is needed, use part number 22744260 and install it at the upper gear box mounting location.

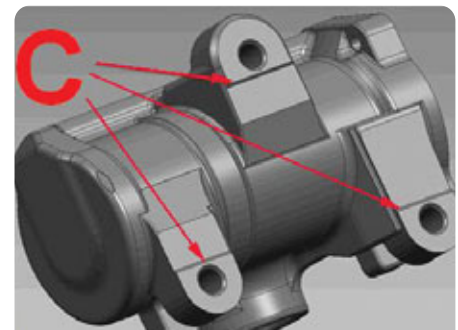

Later production gears had under cuts made to their mounting locations (C).

All production vehicles should have either the shimmed or the undercut mounting tab. If the steering gear is replaced in service, it is important to use the shim only when required.

🙏 Thanks to James Will

GM TechLink is a monthly magazine for all GM retail technicians and service consultants providing timely information to help increase knowledge about GM products and improve the performance of the service department.

**Publisher:**

Thomas J. Arnold  
GM Customer Care and Aftersales  
Thomas.Arnold@GM.com

**Editor:**

Lisa G. Scott  
GM Customer Care and Aftersales  
Lisa.G.Scott@GM.com

**Technical Editor:**

Mark Spencer  
mspencer@gpworldwide.com

**Production Manager:**

Marie Meredith

**Desktop Publishing:**

5by5 Design LLC  
dkelly@5by5dzn.com

**FAX number:**

1-248-729-4704

**Write to:**

TechLink  
PO Box 500  
Troy, MI 48007-0500

**GM TechLink on the Web:**

GM GlobalConnect

General Motors service tips are intended for use by professional technicians, not a "do-it-yourselfer." They are written to inform those technicians of conditions that may occur on some vehicles, or to provide information that could assist in the proper service of a vehicle. Properly trained technicians have the equipment, tools, safety instructions and know-how to do a job properly and safely. If a condition is described, do not assume that the information applies to your vehicle or that your vehicle will have that condition. See a General Motors dealer servicing your brand of General Motors vehicle for information on whether your vehicle may benefit from the information.

Inclusion in this publication is not necessarily an endorsement of the individual or the company.

Copyright © 2011 General Motors  
All rights reserved.

## Detonation/Spark Knock under Light Acceleration

Some 2010 Equinox and Terrain models equipped with the 4-cylinder engine (VIN W, RPO LAF) may exhibit a detonation/spark knock or rattle noise under light acceleration (1,500 to 1,900 rpm). This condition is present under only partial throttle, light load conditions.

A revised calibration has been released to address this condition. Update the ECM using SPS with the latest software available on TIS2Web.

When reprogramming, be sure to update the scan tool with the latest software version and maintain battery voltage using an approved battery charger/maintainer.

☺ Thanks to Ron Caponey

## Sunroof/Sunshade Relearn Tips

The sunroof and/or sunshade on the 2010-2011 LaCrosse may not close or may not close properly when using the express feature.

To determine if the sunroof/sunshade relearn procedure should be performed, connect GDS 2 and select Module Diagnosis > Body Control Module > Data Display. Select Sunroof Data from the drop-down menu and check the lines for Sunroof and Sunshade Not Learned. If either indicates "active," proceed with the next steps.



The sunroof must be learned before the sunshade can be learned. The sunshade may appear to function properly for a time if the sunroof is not learned.

The sunroof and sunshade switches have two detents. Manual indicates the first

switch detent. Use this detent throughout the following procedure.

1. Turn the ignition On, with the engine Off. The LED on the mode switch should be green.
2. To properly learn the sunroof, press the manual open switch (first detent) until the sunroof is open completely. Release the switch.
3. Press and hold the manual open switch again for about 10 seconds. Do not release the switch until the sunroof window is completely closed, finds the hard stop and moves slightly. GDS 2 should now indicate Sunroof Not Learned inactive and the sunroof position should indicate closed. If so, move to the next step. If the sunroof position does not indicate closed, the sunroof is not learned.
4. To properly learn the sunshade, the sunroof glass must be closed and learned. Press the sunshade open switch (first detent) until the sunshade is open completely. Release the switch.
5. Press and hold the manual open switch again for about 10 seconds. Do not release the switch until the sunshade is completely closed, finds the hard stop and moves slightly. GDS 2 should now indicate Sunshade Not Learned inactive and the sunshade position should indicate closed.

☺ Thanks to Christopher Crumb

### Service Know-How

#### 10211.04D Emerging Issues | April 14, 2011

To view Emerging Issues seminars:

Log in to [www.gmtraining.com](http://www.gmtraining.com), select Service Know-How/TECHAssist from the menu, select Emerging Issues, and then Searchable Streaming Video to choose the current Emerging Issues seminar or past programs.



## Car Issues – Fix It Right the First Time

Model Year(s)	Vehicle Line(s)/Condition	Do This	Don't Do This	Reference Information/Bulletin
2011	CTS, CTS-V – Front left and/or right door window slow, binding or inoperative	Adjust door glass	Replace window regulator	PI0354
2011	CTS, CTS-V – Wind noise and/or water leak at front side door glass or mirror patch area(s) and/or visible gap near top of B-pillar or in mirror patch area(s)	Adjust door glass and/or insert foam blocks behind mirror patch	Replace weatherstrip	PI0337A
2009 - 2011	AURA, G6, Malibu – Rattle-type noise in driver's footwell area while driving on coarse pavement and/or gravel roads	Assure the rattle is properly diagnosed. Brake pedal rattle could be mis-diagnosed as steering related	Replace steering or brake components before proper diagnosis	PI0372
2011	Regal – Poor sound quality or muffled sound from radio	Calibrate the radio	Replace the radio, amplifier or speakers	PI0357
2010 - 2011	Impala – Intermittent Service Stabilitrak message displayed on DIC, DTC U1826 71, U1826 72 or U1826 7F set	Check for DTC U1826 and inspect date code on yaw sensor for specified dates	Replace parts without proper diagnosis	PI0371
2011	Cruze – Engine crank/no start due to fuel fouled spark plugs in cold climates, DTCs P0300-P0304	Clean spark plugs on inventory vehicles. Replace plugs on customer-owned vehicles	Replace plugs on inventory vehicles. Most drivers will not experience any problems once they are cleaned	PI0359
2010	Corvette – OnStar antenna becomes loose/detached from windshield	Contact WPC for a replacement bracket	Replace the windshield or re-glue the bracket	PI0099A
2011	Volt – Climate control operation	Educate customer on uniqueness of climate control operation	Replace any hardware or reprogram any modules	PI0353
2011	STS – Navigation radio CD changer is full when no CDs are present	Eject the phantom CDs	Replace the radio	PI0364
2011	Caprice PPV – Fuel door will not open, radio, HVAC, interior lights, remote function actuator and instrument cluster inoperative during disconnect -Transit Isolation Connector must be reconnected after shipping or storage	Verify that the blue Transit Isolation Connector in the rear compartment has been reconnected after shipment or long storage	Repair the radio, HVAC, lights	11-08-45-001
2011	Cruze – Check Engine Light illuminated, one or more DTCs set, coolant found in thermostat connector, wiring harness connectors contaminated with coolant	Inspect thermostat heater wiring connection for signs of coolant leak	Replace any components until the thermostat heater connection is checked for coolant leaks	PI0375
2011	CTS, CTS Sport Wagon – Differential gear whine, hum/whirring noise or pinion gear whine from rear axle	Install prop shaft center support bearing isolator kit	Replace rear drive module, prop shaft or other parts	PI0350A
2011	Regal – Diagnostic information on heated seats inoperative or turn off after one minute, DTC B2425 or B2430 stored	Measure resistance in the heater mats and replace those that are out of specification	Replace heated seat module	PI0377
2011	Cruze, Equinox, LaCrosse, Malibu, Regal, Terrain – Malfunction Indicator Lamp illuminated, DTC P2714, slip or flare when shifting in 2nd or 6th gear	Remove the valve channel plate (402) and the spacer plate (403) from the transmission. Inspect the channel plate and the spacer plate for any debris and clean the valve body thoroughly, making sure that the 2-6 regulator valve (419) moves freely	Replace the transmission without inspecting the valve body, channel plate and spacer plate	PI0376
2010 - 2011	Express, Savana, Sierra, Silverado – Malfunction Indicator Lamp illuminated, poor engine performance with low power, DTC P0299, P0513, P0606, P0622, P207F, P20EE, P2202 and/or P22A0 set	Reprogram ECM with updated calibration	Replace Nox sensor, ECM, or DPF components.	11-06-04-001A



## Truck Issues – Fix It Right the First Time

Model Year(s)	Vehicle Line(s)/Condition	Do This	Don't Do This	Reference Information/Bulletin
2010 - 2011	Equinox, Terrain – Outboard side(s) of rear seat cushion trim cover loose/detached	Add metal retainer clips to the rear seat frame at outboard J-channel locations	Replace the rear seat cushion or cover	PI0365
2011	Sierra, Silverado – Frame labels visible from outside of vehicle	Carefully remove frame labels during PDI	Leave frame labels on at delivery	PI0369
2010	Equinox, Terrain – Detonation, spark knock and/or a rattle noise on light acceleration 1500 to 1900 rpm	Install latest ECM calibration	Replace injectors, fuel pump	PI0325
2010 - 2011	Avalanche, Escalade, Escalade ESV, Escalade EXT, Sierra, Silverado, Suburban, Tahoe, Yukon, Yukon Denali, Yukon XL, Yukon XL Denali – Ring, hum, howl or hoot noise transient with engine rpm (2100, 3100, 4100 rpm)	Install muffler straps	Replace components related to rear axle, drive shaft, exhaust or transfer case	PI0328A
2009 - 2011	Avalanche, Escalade, Escalade ESV, Escalade EXT, Sierra, Silverado, Suburban, Tahoe, Yukon, Yukon Denali, Yukon XL, Yukon XL Denali – Exhaust leak, rattle, rumble and/or noise	Install new clamp	Replace other exhaust components	10-06-05-003A
2010 - 2011	SRX – Squeaking noise from front end while turning steering wheel in cold ambient temperatures	Install new front strut mounts by following updated service replacement procedures found in SI	Replace stabilizer bar bushing for the strut mount concern. It is not necessary to replace front strut assemblies for this noise concern	PI0368
2010 - 2011	Canyon, Colorado – Door ajar lamp illuminates when driving	Locate door switch plunger contact area and install a shim to inner door panel to reduce switch plunger travel	Replace the left door switch or attempt to adjust the door to correct this door ajar light condition	PI0355
2007 - 2011	Acadia, Enclave, OUTLOOK, Traverse – Mirror glass has jerky operation or stops during mirror travel	Lube mirror as instructed	Replace the mirror assembly	10-08-64-003A
2007 - 2011	Avalanche, Escalade, Escalade ESV, Escalade EXT, Sierra, Silverado, Suburban, Tahoe, Yukon, Yukon Denali, Yukon XL, Yukon XL Denali – Front seat cushion cover becomes detached	Modify seat cover channel and add pushpin retainer	Replace seat cover	08-08-50-001C
2011	Acadia, Avalanche, Camaro, CTS, Enclave, Lucerne, Sierra, Silverado, Suburban, Tahoe, Yukon – Accessory remote start does not work with OnStar MyLink phone application	No repair required	Replace the RVS, BSM, or VCIM	PI0360
2008 - 2011	Acadia, Enclave, OUTLOOK, Traverse – Manual seat adjuster bumpy or jerky operation, binds, sticks, seat won't adjust	Repair seat following service procedures	Replace the seat track	10-08-50-005B
2003 - 2006	Escalade, Escalade ESV, Escalade EXT, Suburban, Tahoe, Yukon, Yukon Denali – Borg Warner transfer case drive chain and sprocket revision	Replace both sprockets and chain due to the size change	Use different size sprockets and chain	11-04-21-004
2010 - 2011	SRX – Front suspension noise over bumps in cold weather	Replace the stabilizer bar bushing with the new design bushings. The new bushings will not need to be lubricated with silicon grease	Lube the stabilizer bar bushings	10-03-08-001A
2010 - 2011	Canyon, Colorado – Front seat manual lumbar support adjuster knob loose/falling off	Reposition the front seat cover material so that the lumbar actuator shaft is centered and reinstall the original lumbar knob. Make sure that adjuster knob is fully seated to the actuator shaft with the knob flush to the trim surface	Replace the front seat manual lumbar support adjuster knob/handle or the seat's lumbar actuator shaft	PI0374
2010 - 2011	Express, Savana, Sierra, Silverado – Malfunction Indicator Lamp illuminated, poor engine performance with low power, DTC P0299, P0513, P0606, P0622, P207F, P20EE, P2202 and/or P22A0 set	Reprogram ECM with updated calibration	Replace Nox sensor, ECM, or DPF components.	11-06-04-001A
2009 - 2010	Vibe – Malfunction Indicator Lamp illuminated, DTC P0456 EVAP system very small leak detected	Reprogram PCM	Replace PCM	11-06-04-002
2009 - 2010	Vibe – Malfunction Indicator Lamp illuminated, DTC P0031, P0138 and/or P2195 set	Reprogram PCM	Replace PCM	11-06-04-003